

500'89 Ascend Aeon

● User Manual

Version 00





Copyright © by Bruker Corporation

All rights reserved. No part of this publication may be reproduced, stored in a retrieval system, or transmitted, in any form, or by any means without the prior consent of the publisher. Product names used are trademarks or registered trademarks of their respective holders.

This manual was written by

Peter van Bommel

© December, 2013: Bruker Corporation

Faellanden, Switzerland

ZTKS0157 / Z31921 / 00

For further technical assistance on the NMR Magnet System, please do not hesitate to contact your nearest BRUKER dealer or contact us directly at:

BRUKER BioSpin AG
Industriestrasse 26
CH-8117 Faellanden
Switzerland

Phone: + 41 44 825 91 11
FAX: + 41 44 825 96 96
E-mail: service@bruker.de
Internet: www.bruker.com

0	Contact	9
1	Introduction.....	11
2	Safety	15
3	Transportation	31
4	Assembling	37
5	Operation.....	39
6	Troubleshooting	41
7	Maintenance.....	83
8	Disassembling	87
A	Appendix	89



0	Contact	9
1	Introduction.....	11
1.1	General Information.....	11
1.2	Limitation of Liability	11
1.3	Customer Service.....	11
1.4	Warranty.....	11
1.5	Copyright.....	11
1.6	General View.....	12
2	Safety.....	15
2.1	Approved Persons.....	15
2.2	Customer Responsibilities.....	16
2.3	Key Words.....	17
2.4	Residual Risks.....	18
2.4.1	Persons	18
2.4.2	Intended Use	18
2.4.3	Safety Devices	19
2.4.4	Spare Parts	19
2.4.5	Signs and Labels.....	20
2.4.6	Technical Risks	20
2.5	Personal Protective Equipment.....	26
2.6	Description of Signs and Labels.....	27
2.7	Safety Devices	28
2.8	Behavior in Danger and Emergency Situations.....	30
2.9	Fire Department Notification.....	30
3	Transportation	31
3.1	Safety	31
3.2	Packaging.....	31
3.2.1	Disposal.....	32
3.3	Transport Inspection.....	32
3.4	Transportation by Fork Lift / Pallet Jack.....	33
3.5	Transportation with a Crane	34
3.6	Storing	35
3.7	Disposal.....	35
4	Assembling	37
4.1	Safety	37

Table of Contents

5	Operation.....	39
5.1	Safety	39
5.2	Set into Operation.....	40
6	Troubleshooting	41
6.1	Safety	41
6.2	Problem	42
6.2.1	During Transportation.....	42
6.2.2	During Assembling	42
6.2.3	During Cool Down	44
6.2.4	During Energizing and Shimming.....	48
6.2.5	During Operation of the Magnet Stand.....	50
6.2.6	During Standard Operation.....	52
6.2.7	During De-energizing and Warming up	72
6.2.8	During Operation of the Cryogenic Refrigerator	73
6.3	Troubleshooting Work	78
6.3.1	After a Quench	78
6.3.2	Procedure in case of an alarm signal	80
6.3.3	Procedure in case of Cryogenic Refrigerator failure.....	81
7	Maintenance.....	83
7.1	Safety	83
7.2	Cleaning	84
7.3	Maintenance Timetable	84
7.4	Maintenance Work at the Cryogenic Refrigerator	86
8	Disassembling	87
8.1	Safety	87
A	Appendix	89
A.1	Warning Signs	91
A.2	Figures.....	93
A.3	Tables.....	95
A.4	Glossary / Abbreviations.....	97
A.5	Technical Data MS 500'89 Ascend Aeon	99
A.6	Index.....	125





0 Contact

Manufacturer

Bruker BioSpin AG

Industriestrasse 26

CH-8117 Faellanden

Switzerland

Phone: + 41 44 825 91 11

Fax: + 41 44 825 96 96

<http://www.bruker.com>

E-mail: service@bruker.ch

Please refer to the Model No., Serial No. and Internal Order No. in all correspondence regarding the NMR system or components thereof.

1 Introduction

1.1 General Information

This manual contains important information about the handling of the supplied magnet system used for NMR spectroscopy and its components. The compliance with all safety and handling instructions, the applicable local accident prevention and general safety regulations are necessary for safe work.

This manual is part of the product. It must be kept nearby the magnet system and free access must be ensured at any time. Read the manual carefully before handling the magnet system or its components.

1.2 Limitation of Liability

The information in this manual will take into account the current state of the technology.

The manufacturer assumes no liability for damages resulting from:

- non-compliance with the instructions and all applicable documentation,
- use for purposes not intended,
- not sufficiently approved persons,
- arbitrary changes or modifications and
- use of not approved spare parts or accessories.

1.3 Customer Service

Technical support is provided by Bruker Service via telephone or e-mail. For contact information see page 9 of this document.

1.4 Warranty

The warranty terms can be found in the sales documents of the magnet system and in the Terms and Conditions of Bruker BioSpin AG.

1.5 Copyright

No part of this publication may be reproduced, stored in a retrieval system, or transmitted, in any form or by any means without the prior consent of the publisher. Product names used are trademarks or registered trademarks of their respective holders.

1.6 General View

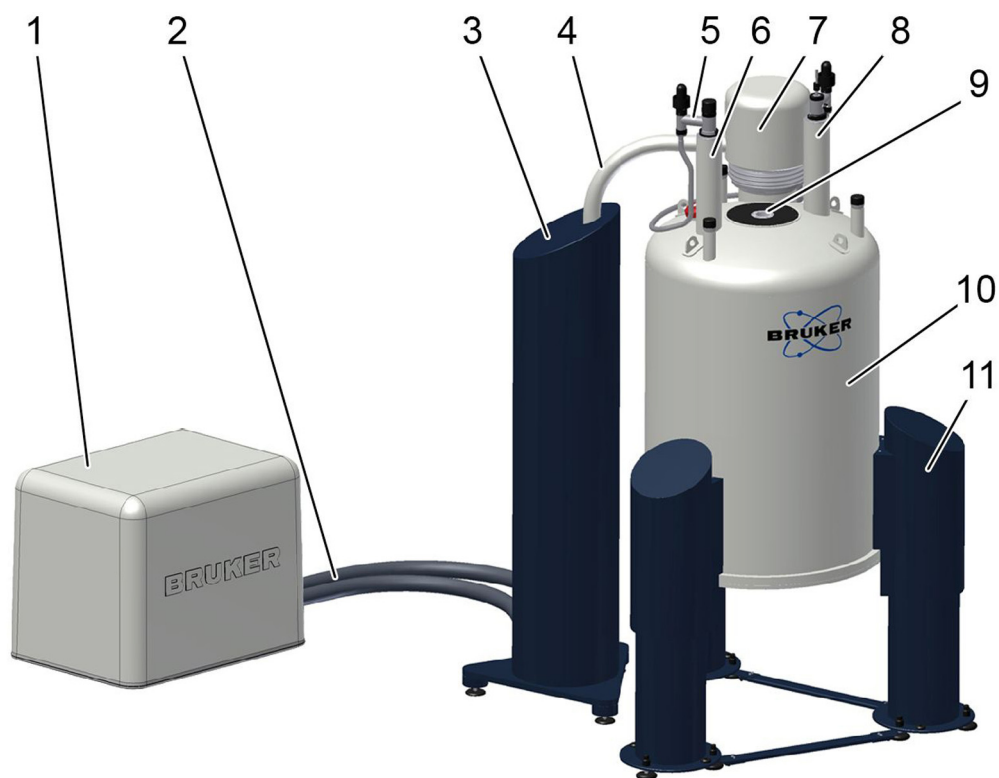

- 1 Cryogenic Refrigerator Compressor
(noise protection cover optionally)
- 2 Cryogenic Refrigerator Flex Lines
- 3 Rotary Valve (RV) covered by the
Rotary Valve Column (RVC)
- 4 Connecting Line
- 5 Helium Flow System
- 6 Current lead turret
- 7 Cryogenic Refrigerator Cold Head
- 8 Helium Fill-in Turret with helium fill-in port
- 9 RT bore
- 10 RT vessel
- 11 Magnet Stand

HELIUM FILL-IN PORT

CAUTION: Use only this port for helium refill!
Don't leave the helium ports open
for more than 5 seconds!
(cf. magnet manual for further information)

Figure 1.1: General view a Magnet System with Aeon /RZ Cryostat

The heart of the NMR magnet system is a superconducting magnet located inside the helium vessel, which is filled with liquid helium. The helium vessel is surrounded by a radiation shield (RS) both cooled by a Cryogenic Refrigerator. The outer casing, the room temperature (RT) vessel (10) contains the helium vessel and the radiation shield. The vacuum inside the RT vessel reduces thermal conduction. The RT bore (9) allows the access to the magnetic center. RT vessel, helium vessel, radiation shield, helium turrets, flow system and the RT bore together build the cryostat of the magnet system.

The cryostat is mounted on a magnet stand (11). The isolators in the magnet stand absorb floor vibrations. Different heights and isolators are available optionally.

The helium turrets (6, 8) connected with the helium flow system (5) are the interface of the helium vessel and the magnet coil. The helium fill-in turret (8) is marked with a yellow label. The current lead turret (6) is the interface for energizing the magnet coil and for diagnostic.

The Cryogenic Refrigerator is a closed loop helium expansion cycle. It consists of a Compressor (1), two Flex Lines (2), a remote Rotary Valve inside the Rotary Valve Column (RVC; 3), a Cold Head (7) and a Connecting Line (4) between Rotary Valve and Cold Head. The Rotary Valve, Flex Lines, Connecting Line and Cold Head are covered with an applicable noise protection cover. For the Compressor a noise protection is available optionally.

Depending on the customers site restrictions several options of the Cryogenic Refrigerator are possible. Refer to the order subscription and to the supplied manuals of the supplied equipment.

2 Safety

The supplied cryostat and further equipment of the magnet system were designed and manufactured according to best available technical knowledge and practice, achieved in over 50 years of experience of Bruker Corporation. International standards for quality and approval recommended for cryostats of superconducting magnets were certified.

Nevertheless non-compliance with the following instructions and safety advice may cause serious hazards and property damage.

2.1 Approved Persons

Bruker BioSpin AG identifies the following qualifications for personnel performing tasks on the magnet system or its components:

Approved Customer Personnel

As a result of professional training by Bruker Service Personnel, experience and knowledge of applicable regulations these persons are qualified to perform the specific tasks on the magnet system and its components assigned to them in this manual. Approved Customer Personnel are qualified to identify possible hazards and risks associated with the tasks assigned to them and to perform all possible steps to eliminate or minimize these risks.

Bruker Service Personnel

These persons are qualified by appropriate qualification and professional training and experience (including all necessary knowledge of applicable regulations and regulatory requirements) to perform specific tasks on the magnet system and its components. Bruker Service Personnel are qualified to identify possible hazards and risks and to perform all possible steps to eliminate or minimize these risks.

2.2 Customer Responsibilities

The customer must obey the security advice and the rules for safety, applicable local accident prevention and environmental protection correctly for the magnet system. Furthermore, the customer is responsible for keeping the magnet system in good technical condition.

In particular:

- The customer must identify additional dangers resulting from the working conditions at the site of the magnet system and provide applicable safety measures.
- The customer must ensure that the site plan meets the specified conditions according to the site planning document for operating the magnet system.
- The customer must clearly mark the danger area around the magnet system and post the corresponding instruction plates.
- The customer has to ensure the intended use of the magnet system.
- The customer has to inform the local fire brigade about the special risks of the magnet system and how to react in the event of an incident.
- The customer must clearly define the responsibilities for operation and maintenance.
- The customer must ensure that all employees working with the magnet system have read and understood the manual.
- The customer has to provide the necessary personal protective equipment for his employees.
- The customer has to instruct his employees at regular intervals on hazards and safety measures.
- The customer has to instruct other persons not working on the magnet system but carrying out work in the same room, for instance cleaning staff or guards about the possible danger at the site of the magnet system.
- The customer has to consider the specific items of this cryostat equipped with a Cryogenic Refrigerator. The customer is responsible for obeying the advice given in this manual. In case the Cryogenic Refrigerator is not running correctly his immediate reaction is mandatory. In case of an unexpected alarm his immediate response is mandatory. For further instruction refer to chapter "**Troubleshooting**" on page 41.
- The customer must ensure that maintenance is performed according to the schedule listed in chapter "**Maintenance Timetable**" on page 84.

2.3 Key Words



DANGER

Indicates a hazardous situation which, if not prevented, will result in death or serious injury.



WARNING

Indicates a hazardous situation which, if not prevented, could result in death or serious injury.



CAUTION

Indicates a hazardous situation which, if not prevented, may result in moderate or minor injury.

NOTICE

Hazard, which could result in property damage.



Information and links for efficient and trouble-free handling and operation.

2.4 Residual Risks

In the following chapter the residual risks from the risk analysis according ISO 14971 are summarized. To prevent health hazards and hazardous situations obey all safety instructions and warnings in the manual.

2.4.1 Persons

WARNING



Risk of injury and property damage due to handling of not approved persons.

Incorrect handling of the magnet system by not approved persons may result in significant bodily injury and property damage.

Thus:

- Work must only be carried out by approved persons with applicable qualifications. The necessary qualifications are specified in the beginning of the relevant chapter.
- In case of doubt, contact Bruker Service. Contact information see page 9 of this document.

2.4.2 Intended Use

The supplied magnet systems is designed and intended for NMR spectroscopy only.

WARNING



Risk of damage to life and limb by incorrect use of the magnet system.

Incorrect use of the magnet system can lead to life-threatening situations and destruction of the magnet system.

Thus:

- Only use the magnet system as intended.
- Do not change the magnet system.
- Do not exceed specified values for operating the magnet system.
- Do not use inserts inside the RT bore not approved by Bruker Service.

Damage claims from damages caused by other than the intended use of the magnet system are excluded and the customer is held liable.

2.4.3 Safety Devices

WARNING



Risk of damage to life and limb due to not sufficient safety devices.

Several safety devices ensure safe operation of the magnet system. They must always be in correct working condition.

Thus:

- Do not block safety devices.
- Do not remove safety devices.
- Check the operational reliability of the safety devices before working on the magnet system.

2.4.4 Spare Parts

WARNING



Risk of injury and property damage from using incorrect or defective spare parts and accessories.

Incorrect or defective spare parts can cause serious injuries. They may cause damaging, malfunctioning and the destruction of the magnet system.

Thus:

- Only use original equipment manufacturer spare parts.
- Only use original equipment manufacturer accessories.

2.4.5 Signs and Labels



WARNING

Risk of damage to persons and property due to not readable signs and labels.

Signs and labels with advice may become not readable.

Thus:

- Maintain signs and labels in a readable state.
- Replace damaged or not readable signs and labels immediately. New signs and labels can be ordered from Bruker Service.

2.4.6 Technical Risks

Magnetic Field



WARNING

Risk of damage to life and limb due to high magnetic fields.

A magnetic field of more than 0.5 mT (5 Gauss) is life-threatening for people with pacemakers or active metal implants. Exposure to more than 8 T can cause damage to health. Duration of exposure (8 h/day) above the limit of 200 mT can cause damage to health. Ferromagnetic tools in the magnetic field are significantly hazardous. Disks and electronic devices may be damaged.

Thus:

- Mark the magnetic field of more than 0.5 mT (5 Gauss) before start up.
- Keep people with active medical implants away from the 0.5 mT (5 Gauss) area.
- The permanent workplace of employees must be outside the 0.5 mT (5 Gauss) area.
- Do not stay or work at magnetic fields of more than 8 T.
- Prevent exposure of more than 200 mT for more than 8 h/day.
- Keep disks, credit cards and electronic devices away from the identified area.
- Do not use ferromagnetic tools or items within the identified area.
- Only use non-ferromagnetic transportation dewars or pressure cylinders for the cryogenic agents.
- Only use non-ferromagnetic ladders or steps.

Cryogenic Agents

WARNING

Risk of damage to life and limb due to cryogenic agents.

Risk of damage to life and limb due to not correct handling of liquid cryogenic agents. Within the transition from liquid to gas, helium and nitrogen expands their volume, causing closed vessels or transportation dewars to burst. The evaporating cryogenic agents will displace the breathing air. Helium displaces the breathing air in the upper part of the room, nitrogen displaces the breathing air in the lower parts of the room. In case of not sufficient ventilation this may result in death by suffocation.

Liquid and gaseous cryogenic agents are extremely cold. Contact with liquid or gaseous cryogenic agents will lead to cold burns. Contact with the eyes may cause blindness. Refer to Warning: Low Temperature on page 23.

Thus:

- Only use cryogenic agents in well ventilated rooms. In case of doubt ask Bruker Service.
- Wear an oxygen monitor on the body during service and maintenance work.
- Prevent any skin contact with liquid or gaseous cryogenic agents.



Electricity

WARNING

Risk of damage to life and limb due to electricity.

Risk of damage to life and limb due to contact with electrical lines and damaged insulation.

Thus:

- Work on electrical equipment must be done by an approved electrical technician.
- Keep moisture away from electrical lines to prevent short-circuits.
- Check the magnet system electrical grounding before start.
- Switch the power OFF before working on the Bruker Power Supply or further equipment.



Quench



WARNING

Risk of suffocation during a quench of the magnet system.

A quench is the very fast de-energizing of the magnet by loss of its superconductivity. The stored magnetic energy is converted into heat and thus large quantities of helium evaporate. The evaporating helium will displace the breathing air. In case of not sufficient ventilation this may result in death by suffocation.

Thus

- The magnet system site must be well ventilated. In case of doubt contact Bruker Service.
- The evaporating gas may resemble smoke. Never pour water on the magnet system.

Gas under Pressure



WARNING

Risk of injury due to gas under pressure inside the cryostat and further equipment.

The helium vessel of the cryostat may get sealed off due to ice formation inside the helium turrets in case of non-compliance with the instruction given in this manual. This may lead to overpressure and damage of the helium or the nitrogen vessel.

Manipulations of components with gas under pressure may lead to injury and property damage.

Thus:

- In case of icing inside the helium turrets contact Bruker Service immediately.
- Release the pressure to the recommended value before working on components with gases under pressure.
- Do not seal cryogenic agent vessels of the cryostat or the transportation dewars.
- Do not connect high pressure transportation dewars to the cryostat. Completely eliminate the high pressure from the transportation dewars before connecting and transferring cryogenic agents.
- Keep the Cryogenic Refrigerator circuit closed at any time. Overpressure can release with the safety valves of the compressor, of the rotary valve and of the cold head.

Low Temperatures

WARNING



Risk of injury due to low temperatures of liquids and metal parts.

Physical contact with extremely cold liquids and metal parts may cause serious injuries. Contact with the skin may cause cold burns. Contact with the eyes may cause blindness.

Thus:

- Always wear protective goggles, protective gloves and protective clothes while handling with liquid cryogenic agents or metal parts in contact with liquid cryogenic agents.
- Protect temperature sensitive components such as O-rings from contact with liquid cryogenic agents.

Spontaneous Ignition and Explosion

WARNING



Risk of injury from spontaneous ignition and explosion caused by liquid oxygen.

Pure oxygen condenses on extremely cold metal pieces. Together with oil it may ignite spontaneously. In case of fire the pure oxygen may cause an explosion.

Thus:

- Do not smoke near the magnet system.
- Do not use open flames near the magnet system.
- Keep the environment around the magnet system clean.
- Do not leave oily rags near the magnet system.

Risk of Slippage

WARNING



Risk of injury from slippage.

The accumulation of condensed water on the floor and ladders causes slippery surfaces.

Thus:

- Always wear safety shoes with an anti-slip sole.
- Be careful using ladders.
- Clean floor and ladders regularly.

Risk of Tilting



WARNING

Risk of injury due to tilting of the magnet system.

The magnet system is very sensitive to lateral forces. It may tilt.

Thus:

- Do not climb onto the magnet system.
- Do not lean items against the magnet system.
- Do not lean against the magnet system.
- Do not move the magnet system on your own.

Heavy Weights



WARNING

Risk of damage to life and limb caused from heavy weights.

Lifting heavy weights is life-threatening due to falling or moving parts.

Thus:

- Do not stay or work under a lifted magnet system.
- All used lifting equipment must be approved to carry the weight (see **Appendix, Technical Data**).
- Do not use damaged lifting equipment.
- Do not use lifting equipment without updated check tag.
- Lifting only with approved qualification.
- Obey ergonomic guidelines while lifting heavy parts.
- Protect parts against falling.
- Always wear safety shoes with approved toe caps.

Risk of Hot Surfaces**! WARNING****Risk of injury from contact with hot or cold surfaces.**

Surfaces of the Cryogenic Refrigerator parts may be hot. Skin contact with these surfaces can cause serious injuries.

Thus:

- Any work at the Cryogenic Refrigerator parts must only be performed by Bruker Service.
- Always wear protective gloves while handling Cryogenic Refrigerator parts.

Transportation**! CAUTION****Risk of injury and property damage due to incorrect transportation.**

The boxes may tilt, movement may get out of control. Thus persons may get injured and the cryostat or further equipment may be damaged.

Thus:

- Be careful while unloading and moving the boxes.
- Do not move the boxes arbitrarily.
- Pay attention to all symbols on the boxes.
- Pay attention to sharp edges and spikes of boxes and parts by using protective gloves while moving.
- Move the boxes in an upright position.
- Do not tilt the boxes.
- Prevent crossing thresholds, even if they are only a few millimeters high.
- Clean the transportation way before moving the box.
- Unpack shortly before assembling.
- The cryostat or further equipment must be protected from rain and other bad weather conditions during transportation.
- Exclusively move the cryostat in its original box.
- Do not remove the tightening straps inside the box until assembling.
- Only use the attachment points provided.
- Ensure that the cryostat is always leveled during any transportation.
- Transportation only with transportation locks attached.
- Do not move the evacuated cryostat.
- Do not move the cryostat after cool down.

2.5 Personal Protective Equipment

The personal protective equipment must be worn at any time while working on the magnet system and further equipment to prevent health hazards.



Protective Goggles

Used to protect the eyes from injury due to flying cold liquids and parts.



Protective Gloves

Used to protect the hands from injury caused by contact with extremely cold liquids or surfaces and for protection from injury caused by rough edges.



Protective Clothes

Used to protect the body from injury caused by contact with extremely cold liquids or surfaces and for protection from wounds.



Safety Shoes

Used to protect the feet from injury from falling of heavy objects. An anti-slip sole protects from injury caused by slipping and falling on slippery floor and steps. Only use safety shoes with non-ferromagnetic toe caps.



Portable Oxygen Monitor and Alarm

Used to warn against low oxygen concentrations in surrounding air.

2.6 Description of Signs and Labels

Signs and labels are always related to their immediate vicinity. The following signs and labels are found on the magnet system and in the vicinity.



Prohibition sign: No person with pacemakers!

People with pacemakers are endangered in the identified area of 0.5 mT (5 Gauss) and are not allowed to enter these areas.



Prohibition sign: No person with implants!

People with metallic implants are endangered in the identified area of 0.5 mT (5 Gauss) and are not allowed to enter these areas.



Prohibition sign: No watches or electronic devices!

Watches and electronic devices may be damaged in the identified area of 0.5 mT (5 Gauss).



Prohibition sign: No credit cards or other magnetic memory!

Credit cards and magnetic memory may be damaged in the identified area of 0.5 mT (5 Gauss).



Prohibition sign: Do not touch! Do not block!

Do not touch or block the identified area.



Hazard warning sign: Strong magnetic field!

- No magnetic memory.
- No jewelry.
- No metallic items.



Emergency exit!

- Always keep the emergency exit clear.
- Follow the arrows if necessary.
- Doors must be pushed open in escape direction.

2.7 Safety Devices

The supplied cryostat of the magnet system is equipped with the following safety devices:

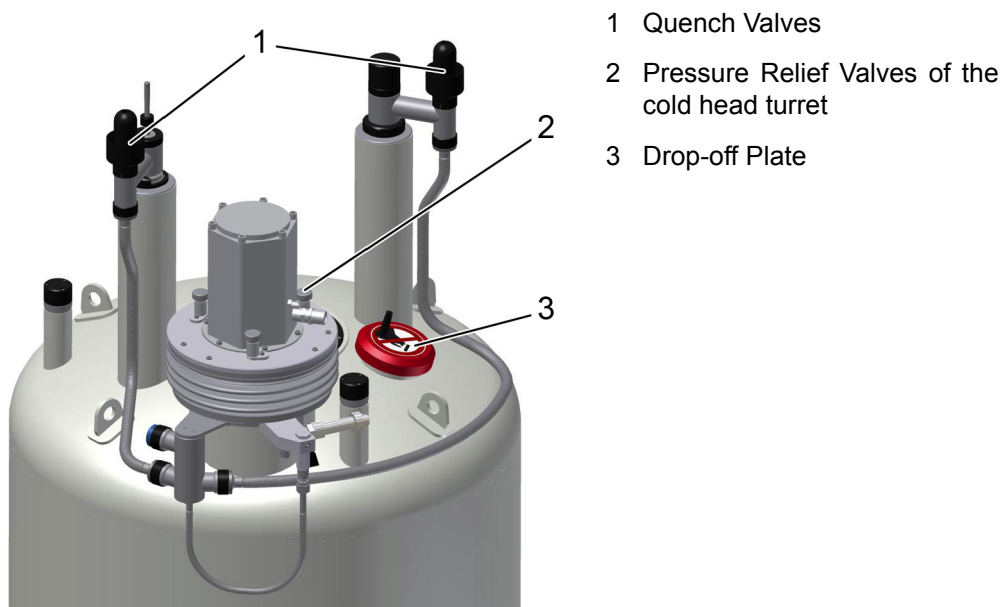

Figure 2.1: Safety Devices of the RZ Cryostat

Quench Valve

The quench valves (1) are the safety devices of the helium vessel. They open with a defined pressure. In case of an accidental overpressure in the helium vessel the quench valves will release the pressure smoothly.

Pressure Relief Valve

The pressure relief valve (2) is the safety device of the cold head turret. It opens with a defined pressure. In case of an accidental overpressure in the cold head turret the pressure relief valve will release the pressure smoothly.

Drop-off Plate

The drop-off plate (3) is a safety device of the RT vessel. If the vacuum breaks, the drop-off plate will open. In case of an accidental overpressure in the RT vessel the drop-off plate will release the pressure smoothly.

Cryogenic Refrigerator Parts

For information about the safety devices of the Cryogenic Refrigerator parts refer to the supplied separate manual.

2.8 Behavior in Danger and Emergency Situations

Preparations

- Keep the emergency exits free at all times.
- Prepare and maintain an up-to-date list of emergency telephone numbers in the magnet system area.

In Case of Emergency

- Leave the danger zone immediately.
- Check for sufficient ventilation in the room before entering, especially if people are showing symptoms of suffocation.
- Rescue persons from the danger zone.
- Provide medical attention for people with symptoms of suffocation.
- Start first aid immediately.
- Call the responsible contact.
- Call for medical assistance.
- Call the fire department.

First Aid for Cold Burns

- Help the injured persons to lie down comfortably in a warm room.
- Loosen all clothing which could prevent blood circulation in the injured area.
- Pour large quantities of warm water over the affected parts.
- Cover the wound with dry and sterile gauze.
- In case of contact of liquid cryogenic agents with the eyes rinse thoroughly with clean water.
- Call for medical assistance.

2.9 Fire Department Notification

- Inform the fire department about the potential risks of a magnet system, like danger due to ferromagnetic rescue equipment near the magnet system.
- Laboratory windows which are accessible during an emergency should be clearly identified with warning signs, visible from the outside.
- Inform the fire department about the characteristics of a quench to prevent confusion with smoke.
- Never pour water over the magnet system during a quench!

3 Transportation

3.1 Safety

The transportation is carried out by Bruker Service or approved persons. However, it may happen that other persons have to receive the delivery of the shipping boxes. In this case it is essential to obey the instructions in this chapter and to inform these persons before.



WARNING

Heavy Weights (see [page 24](#))



CAUTION

Transportation (see [page 25](#))

3.2 Packaging



The cryostat is supplied in a wooden box on a pallet. It is secured inside with straps against tilting and moving.

Accessories such as the flow systems, level sensors and bore tubes are in the side compartment of the box.

The Cryogenic Refrigerator parts and the Flex Lines are supplied in boxes on a pallet.

The Magnet Stand is supplied in a wooden box on a pallet.

Figure 3.1: Packaging (without surrounding panels)

3.2.1 Disposal

Keep the original boxes for future transportation.

If no further transportation is planned, dispose of the boxes according to environmentally friendly regulations.

3.3 Transport Inspection

Investigate the delivery with regard to visible damage and completeness of delivery.

Transport control systems

The shipping and handling monitors (“Shock Watch“, “Tilt Watch“) on the boxes show if the boxes were kicked or tilted during transportation.

Checks

Shock Watch: Follow instructions on the label.

Tilt Watch: Follow instructions on the label.

In case of damage

- Accept delivery with reservation.
- Make a documentation of all observable damage and add it to the transportation documents.
- Start complaint process.
- Contact Bruker Service before installation.

i The claim for damage expires after the fixed period.

Thus:

Report damages to Bruker Service immediately after detection of damage. For contact information see page 9 of this document.

3.4 Transportation by Fork Lift / Pallet Jack

A fork lift is recommended for transporting the boxes to the installation site.

Approved Persons: Approved forklift / pallet jack operator

Precondition: The fork lift / pallet jack must be approved for the transportation weight (refer to the supplied Sales Information).

Transport



Figure 3.2: Transportation by forklift - front side

1. Check the route of transport for the minimal height and width.
2. Check sufficient floor capacity on the route of transport. In case of doubt ask a stress analyst.
3. Check sufficient carrying capacity while using an elevator.
4. Position the forks between the bars of the box as shown in the figure. Make sure the side towards the operator is the one with the labels on it.



Figure 3.3: Transportation by forklift - rear side

5. Make sure the forks of the fork lift are longer than the box and projects out of the back of the box as shown in the figure.
6. Now lift the fork and move the box to the site.

3.5 Transportation with a Crane

A crane is recommended for lifting the cryostat out of the box.

Approved Persons: Approved crane operator

Precondition: The crane must be approved for the transportation weight (see chapter **Appendix, Technical Data**).

Attachment Points

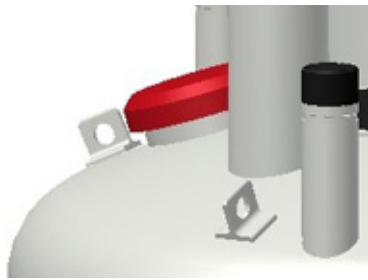

1. Exclusively use the marked eyelets as attachment points for the lifting equipment.
2. Use all eyelets for the lifting equipment.

Figure 3.4: Attachment points for lifting equipment

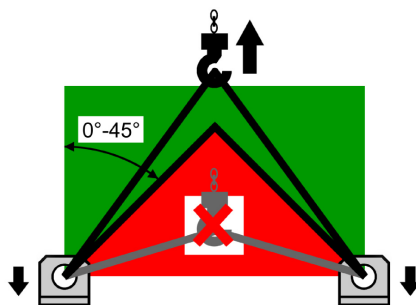

3. Follow the instructions on the label on top of the cryostat. This label gives important information about correct attachment and transportation.
4. Check for correct fastening of the lifting equipment before lifting the cryostat.
5. Make sure that any movement of the crane is as slowly as possible to avoid any damage due to acceleration.
6. Check for correct leveling of the cryostat while hanging on the crane.

Figure 3.5: Instruction label for lifting equipment

3.6 Storing

If it is necessary to store the cryostat and accessories before installation obey the following instructions:

- Store the boxes in a closed, dry and dust-free room.
- Store the boxes upright.
- Do not tilt the boxes.
- Do not unpack the supplied boxes.
- Prevent mechanical vibrations to the boxes.
- Storage temperature: 5 - 40 °C.
- Storage humidity: less than 50% @ 23 °C.

3.7 Disposal

For disposal after the life cycle please contact Bruker Service for further information. For contact information see page 9 of this document.

4 Assembling

4.1 Safety

Approved Persons: Bruker Service only

5 Operation

5.1 Safety

Approved Persons

Bruker Service, Approved Customer Personnel

WARNING



Magnetic Fields (see [page 20](#))

Cryogenic Agents (see [page 21](#))

Electricity (see [page 21](#))

Gas under Pressure (see [page 22](#))

5.2 Set into Operation

Mount the further equipment of the supplied magnet system respecting their manuals.



Figure 5.1: Start the Magnet Stand

Set the magnet stand into operation by switching the pneumatic controller to UP position.



Figure 5.2: Stop the Magnet Stand

For any work at the magnet system like maintenance or refill of helium stop the magnet stand by switching the pneumatic controller to DOWN position.

6 Troubleshooting

Troubleshooting must be performed only with approved qualification.

In case of doubts or problems not specified in the following list contact Bruker Service immediately. For contact information see page 9 of this manual.

6.1 Safety

Approved Persons

Bruker Service, Approved Customer Personnel

WARNING



Magnetic Fields (see [page 20](#))

Cryogenic Agents (see [page 21](#))

Electricity (see [page 21](#))

Gas under Pressure (see [page 22](#))

Spontaneous Ignition and Explosion (see [page 23](#))

Personal protective equipment

- Protective goggles
- Protective gloves
- Protective clothes
- Safety shoes

6.2 Problem

6.2.1 During Transportation

Indicator	Possible reason	Solution	By
Tilt Watch / Shock Watch activated.	Careless transportation.	<ol style="list-style-type: none"> 1. Accept delivery with reservation. 2. Remark the extent of damage in the transportation documents. 3. Start complaint process. 	Approved Customer Personnel
Visible damage.	Careless transportation.	<ol style="list-style-type: none"> 1. Accept delivery with reservation. 2. Remark the extent of damage in the transportation documents. 3. Start complaint process. 	Approved Customer Personnel

6.2.2 During Assembling

Indicator	Possible reason	Solution	By
Ceiling height too low for assembling on magnet stand.	Site does not meet the required conditions.	Choose another site that meets the required conditions.	Bruker Service
Ceiling height too low for inserting the Helium Level Sensor.	Site does not meet the required conditions.	Insert the Helium Level Sensor before mounting the magnet stand.	Bruker Service
Helium bore tube and radiation shield are not concentric.	Alignment is not correct.	Check fixation of the alignment rods.	Bruker Service

Continued on next page

Continued from page before

Indicator	Possible reason	Solution	By
Helium bore tube and radiation shield are not concentric.	Alignment rod is loose or broken.	Replace alignment rod ^a .	Bruker Service
	Reduction flange is not concentric.	Check orientation.	Bruker Service
Vacuum Valve collides with the magnet stand.	Vacuum Valve mounted incorrect.	Turn the Vacuum Valve. Be careful if the RT vessel is evacuated.	Bruker Service
Vacuum in RT vessel does not reach 5×10^{-5} mbar in 48 hours.	O-rings may be damaged.	Check and clean O-rings and slots; replace O-rings if necessary: <ul style="list-style-type: none"> • of the Vacuum Valve • of the drop-off plate • of the reduction and sealing flanges • of the bottom plate ^a 	Bruker Service
	Defective pumping unit or pumping line.	Check pumping unit and pumping line: A pressure below 10^{-6} mbar must be reached with a closed sealing plug. Replace if necessary.	Bruker Service
	Room temperature bore tube has scratches or dust on the sealing surfaces.	Check sealing surfaces on the room temperature bore tube: No scratches and no dust should be visible.	Bruker Service
	Moisture within the RT vessel.	Pump and flush the RT vessel several times with dry nitrogen gas.	Bruker Service
Super insulation touches RT vessel or bore tube or radiation shield.	Super insulation was not fixed correctly during assembly.	Fix super insulation on the outer radiation shield with polyester tape ^a . Carefully prevent any connection between different vessels or bore tubes in the cryostat.	Bruker Service

^a. For this work the bottom plate has to be removed. Check the suspension tubes of the helium vessel are not broken. Install the safety device for fall protection (not supplied). Contact Bruker Service for further information.

6.2.3 During Cool Down

Indicator	Possible reason	Solution	By
Precooling with liquid nitrogen continue too slowly.	Empty transportation dewar.	Refill or replace transport dewar.	Bruker Service
	Transfer pressure too low.	Increase transfer pressure slightly.	Bruker Service
	Transportation dewar is leaky; no transfer pressure may be applied.	Check transportation dewar and change if necessary.	Bruker Service
Precooling with liquid nitrogen continue too quickly.	Transfer pressure too high.	Stop precooling. Adjust correct transfer pressure.	Bruker Service
Vacuum in RT vessel does not reach 5×10^{-5} mbar in 48 hours.	O-rings may be leaky.	Check and clean O-rings and slots; replace O-rings if necessary: <ul style="list-style-type: none"> • of the Vacuum Valve • of the drop-off plate • of the reduction and sealing flanges • of the bottom plate ^a 	Bruker Service
	O-rings may be frozen due to contact with liquid nitrogen.	<ol style="list-style-type: none"> 1. Stop precooling. 2. Warm up O-ring with warm air 3. Wait until the vacuum is recovered. 4. Prevent liquid nitrogen from splashing on O-rings. 	Bruker Service
	Defective pumping unit or pumping line.	Check pumping unit and pumping line: A pressure below 10^{-6} mbar must be reached with a closed sealing plug. Replace if necessary.	Bruker Service

a. see note on page before

Continued on next page

Continued from page before

Indicator	Possible reason	Solution	By
RT vessel becomes cold and wet.	Vacuum is broken or less than 1×10^{-3} mbar.	<ul style="list-style-type: none"> Do not remove pumping unit until filling with liquid helium is finished. Continue as in problem <i>Vacuum in RT vessel does not reach 5×10^{-5} mbar</i> above 	Bruker Service
	Cold leak after transportation.	<ol style="list-style-type: none"> Stop cool down. Warm up cryostat. 	Bruker Service
Cold spot in the RT-bore.	Alignment not correct.	<ol style="list-style-type: none"> Stop cool down. Warm up cryostat. Align the vessels. 	Bruker Service
The helium flow system becomes very cold and icy during pumping and flushing with helium gas.	liquid nitrogen remains in the helium vessel, boiling off strongly during pumping.	<ol style="list-style-type: none"> Stop pumping. Carefully remove all liquid nitrogen through the precooling tube. Check with the dipstick to be sure that the helium vessel is completely empty of liquid nitrogen and of frozen nitrogen (nitrogen ice). 	Bruker Service
After some intervals of pumping and flushing it is not possible to reach a vacuum in the range of 1 mbar.	The globes in the quench valves are not fitting correctly in the O-rings and thus the quench valves are leaky.	<ol style="list-style-type: none"> Stop pumping. Remove frozen air and frozen moisture with warm helium gas. Slightly grease the O-rings and check the position of the globes. Check with the dipstick to be sure that the helium vessel is completely empty of liquid nitrogen and of nitrogen ice. 	Bruker Service
	Liquid nitrogen remains in the helium vessel, boiling off strongly during pumping.	<ol style="list-style-type: none"> Stop pumping. Carefully remove all liquid nitrogen through the precooling tube. Check with the dipstick to be sure that the helium vessel is completely empty of liquid nitrogen and of frozen nitrogen (nitrogen ice). 	Bruker Service

Continued on next page

Continued from page before

Indicator	Possible reason	Solution	By
Nitrogen ice in the helium vessel.	Pumping intervals during pumping and flushing were too long and remaining nitrogen was boiling off and got frozen.	<ol style="list-style-type: none"> 1. Warm up the magnet coil with warm helium gas through the precooling tube until the whole coil is warmer than 90 K. 2. Repeat pumping and flushing and carefully check with the dipstick to be sure that the helium vessel is completely empty of liquid nitrogen and of frozen nitrogen (nitrogen ice). 	Bruker Service
Transfer of liquid helium does not start.	Empty transportation dewar.	Refill or replace transportation dewar.	Bruker Service
	The transfer pressure in the transportation dewar is too low.	Increase the transfer pressure.	Bruker Service
	The transportation dewar is leaky, there is no transfer pressure built up.	Check the transportation dewar for leakage. Re-tighten all connections.	Bruker Service
	The siphon or the helium transfer line are blocked with ice.	Check the siphon and helium transfer line for blockages, remove ice with warm helium gas.	Bruker Service
The cool down of the magnet coil does not continue although helium is transferred.	The helium transfer line is defective.	Check the helium transfer line for icing. If there are cold spots visible, replace the helium transfer line.	Bruker Service
	The extension is not mounted on the helium transfer line.	Mount the extension piece on the helium transfer line. Check the helium transfer line to be inserted completely into the siphon.	Bruker Service

Continued on next page

Continued from page before

Indicator	Possible reason	Solution	By
The zero reading of the Helium Level Sensor can not be adjusted at the beginning of cooling down with liquid helium.	The Helium Level Sensor is not connected correctly with the connector in the helium flow system.	Check the connection in the helium fill-in turret between Helium Level Sensor and connector.	Bruker Service
	The Helium Level Sensor is defective.	Check the Helium Level Sensor with the 0% calibration plug.	Bruker Service
The helium level does not reach 100% after cooling down.	Empty transportation dewar, helium transfer stopped.	Refill or replace transportation dewar.	Bruker Service
	The Helium Level Sensor is disturbed by the transfer line's extension piece.	<ol style="list-style-type: none"> 1. Stop the liquid helium transfer. 2. Remove the transfer line. 3. Measure the helium level after some minutes without the transfer line. 	Bruker Service
After cool down the helium boil off is higher than specified (up to 5 times).	Usual behavior. A few days are necessary for the radiation shields and the insulation to reach scheduled temperatures.	Wait a few days and check helium boil off. The presence of the current lead in the current lead turret during energizing and shimming helps to cool down the radiation shield due to higher helium flow.	Bruker Service
Temperature of the radiation shield decreases too slowly (if $T_{RS} > 250$ K after pre-cooling with liquid nitrogen)	Cryogenic Refrigerator not operating.	Start Cryogenic Refrigerator.	Bruker Service
	Cryogenic Refrigeration operating not correct	See " During Operation of the Cryogenic Refrigerator " on page 73.	Bruker Service
2 days after cool down the T_{RS} is still higher than set value (alarm of CMU)	Cryogenic Refrigerator performance not sufficient.	See " During Operation of the Cryogenic Refrigerator " on page 73.	Bruker Service
	Alarm default settings of the CMU or MICS not correct.	Check set values (see separate manual of the CMU and of the MICS)	Bruker Service
	Cold head not mounted correctly.	See " Mounting the Cryogenic Refrigerator Parts " on page 54.	Bruker Service

6.2.4 During Energizing and Shimming

Indicator	Possible reason	Solution	By
The current lead can not be inserted completely into the connector.	The connector is covered with ice. (frozen moisture or nitrogen ice).	Carefully remove the ice with warm helium gas. To remove small ice spots use the dipstick or the precooling tube as tubing for the warm helium gas.	Bruker Service
	The shorting plug was not removed.	Remove the shorting plug with the shorting plug tool.	Bruker Service
	The orientation of the current lead is not correct.	Turn the current lead carefully until it can be inserted correctly into the connector.	Bruker Service
Main coil heater test fails.	Power Supply defective.	Replace the Power Supply.	Bruker Service
	Connector or cables defective.	Clean connectors or replace cables if necessary.	Bruker Service
Setting of sense voltage fails.	The main coil heater switch is "OFF". The main coil switch is not opened.	Switch the main coil heater to "ON" and check the main coil heater current to be adjusted correctly.	Bruker Service
	The main coil heater current is not correct. The main coil switch is not opened.	Adjust main coil heater current correctly.	Bruker Service
	The auxiliary shorting plug is inserted in the current lead turret by mistake and makes a short circuit across the main coil.	Remove the auxiliary shorting plug and insert it in the helium fill-in turret.	Bruker Service
Current lead can not be removed.	The connector is covered with ice (frozen moisture or nitrogen ice).	Carefully remove the ice with warm helium gas over the helium flow system. To remove small ice spots from the connector use the dipstick or the precooling tube as tubing for the warm helium gas.	Bruker Service

Continued on next page

Continued from page before

Indicator	Possible reason	Solution	By
Shorting plug can not be removed.	The connector is covered with ice (frozen moisture or nitrogen ice).	Carefully remove the ice with warm helium gas. To remove small ice spots use the dip-stick or the precooling tube as tubing for the warm helium gas.	Bruker Service
The magnet system quenches	Loss of superconductivity.	See "After a Quench" on page 78.	Bruker Service
	The helium level was too low for energizing, cycling, shimming, de-energizing.	See "After a Quench" on page 78.	Bruker Service
	The Power Supply is defective. The main current is oscillating.	Replace the Power Supply.	Bruker Service
The main coil switch can not be closed on field.	The helium level is too low for energizing. The main coil switch is not covered with liquid helium.	Never try to energize the magnet with less than the "minimum level during energizing" in the helium vessel.	Bruker Service
	The Power Supply is defective. The main current is oscillating.	Replace the Power Supply.	Bruker Service
Shim current can not be set correctly.	The control cable is not connected correctly to the current lead or to the Power Supply.	Connect the control cable correctly to current lead and Power Supply.	Bruker Service
	Switch „Main Coil/OFF/Shim Coil“ in wrong position.	Change the switch position	Bruker Service
Shims do not affect the NMR signal.	Shim heater current is not correct. The shim switches are not opened.	Set the shim heater current to the specified value (see Appendix Technical Data)	Bruker Service

Continued on next page

Continued from page before

Indicator	Possible reason	Solution	By
Magnet system does not reach specification.	Magnetic material inside RT bore tube.	Carefully clean the RT bore tube.	Bruker Service
	Large ferromagnetic parts near the magnet system.	<ol style="list-style-type: none"> 1. Keep the maximum possible distance between the magnet system and ferromagnetic parts. 2. Repeat shimming. 	Bruker Service

6.2.5 During Operation of the Magnet Stand

In case of doubt contact Bruker Service and refer to the manual of the Magnet Stand

Indicator	Possible reason	Solution	By
The NMR spectrum shows massive disturbances.	The pneumatic controller is in DOWN position.	Switch pneumatic controller to UP position.	Approved Customer Personnel
	Magnet system has direct mechanical contact with the floor via accessories or cables.	Identify and eliminate contact point. Arrange cables in loose S- or U-shapes.	Approved Customer Personnel
		If the problem is still not solved, contact Bruker Service.	Approved Customer Personnel
	Magnet system has physical contact to the magnet stand.	Check leveling; adjust if necessary.	Bruker Service
	Piston of the isolator is not centric or touches its casing.	Align magnet stand.	Bruker Service
	T-safety brackets touches the pillar.	Align magnet stand.	Bruker Service
	Floor vibrations in horizontal and vertical direction.	Replace air damped isolators with air piston isolators.	Bruker Service

Continued on next page

Continued from page before

Indicator	Possible reason	Solution	By
The isolator of the magnet stand does not reach the operating position.	Pneumatic controller in DOWN position.	Switch pneumatic controller to UP position.	Approved Customer Personnel
	The pressure of the gas supply is too low.	Check the pressure of the gas supply. It must be in the range of 5 to 8 bar (70 to 112 psi).	Approved Customer Personnel
		If the problem is still not solved, contact Bruker Service.	Approved Customer Personnel
	The magnet system is not leveled correctly.	Switch of the pneumatic isolators. Check the leveling of the cryostat.	Bruker Service
	Defective leveling valve.	Replace leveling valve or isolator.	Bruker Service
	Defective membrane of an isolator.	Replace leveling valve or isolator.	Bruker Service
Magnet system achieves working position jerkily.	Piston is not centric or touching its casing.	Align magnet stand.	Bruker Service
Audible loss of gas.	Defective membrane or defective leveling valve of an isolator.	Replace leveling valve or isolator.	Bruker Service
	Hose connector is defective or loose.	Insert hoses correctly and tighten screws.	Bruker Service
Velocity of lifting or lowering too high.	Wrong adjustment of the flow control valve.	Close restrictor of the flow control valve completely; then open it a half turn.	Bruker Service

6.2.6 During Standard Operation

Indicator	Possible reason	Solution	By
The helium boil off decreases to zero.	The helium flow system is covered with ice.	Contact Bruker Service immediately! Do not try to remove ice of the helium flow system!	Approved Customer Personnel
	⚠ WARNING: Cryogenic Agents Quench		
	The helium flow system or the suspension tubes are blocked with ice.	Blow in warm helium gas carefully through an applicable tube. Do not insert it more than 600 mm from the top of the helium turrets.	Bruker Service
The helium boil off is too high.	The Helium Level Sensor is permanently on (service mode) or used often.	Switch off Helium Level Sensor. Reduce helium level measurement (during measuring of the helium level an amount of helium boils off due to the heat input of the Helium Level Sensor.	Approved Customer Personnel
	The atmospheric pressure is decreasing.	Usual behavior. Watch helium boil off daily.	Approved Customer Personnel
		If the problem is still not solved, contact Bruker Service.	Approved Customer Personnel

Continued on next page











Continued from page before

Indicator	Possible reason	Solution	By
Continue of: The helium boil off is too high.	Vacuum reduced.	Rebuild vacuum, see "Rebuilding Vacuum" on page 52	Bruker Service
	The radiation baffles are not inserted in the current lead turret.	Insert the radiation baffles into the current lead turret.	Bruker Service
Quench	Loss of superconductivity.	See "After a Quench" on page 78 Contact Bruker Service immediately!	Approved Customer Personnel
Cold spots within the RT bore.	Alignment not correct.	Contact Bruker Service.	Approved Customer Personnel
RT vessel is wet and cold.	Vacuum reduced.	Contact Bruker Service immediately!	Approved Customer Personnel
Not correct helium level warning from MICS GUI.	Helium Level Sensor defective.	Contact Bruker Service immediately!	Approved Customer Personnel
Helium level at constant level, no change during days.	Helium Level Sensor defective.	Contact Bruker Service immediately!	Approved Customer Personnel
		⚠ WARNING: Low Temperature	
Not correct helium level warning out of MICS GUI.	Helium Level Sensor defective.	Replace Helium Level Sensor (see "Replacement of the Helium Level Sensor" on page 126)	Bruker Service
Helium level at constant level, no change during days.	Helium Level Sensor defective.	Replace Helium Level Sensor (see "Replacement of the Helium Level Sensor" on page 126)	Bruker Service

Troubleshooting

The following information you might find during standard operation of the magnet system. The display and interfaces of CMU and MICS are on the left side, the corresponding reason and solution is in the same row on the right side.

The alert message given by e-mail gives detailed information on which sensor value is out of limit. For further information refer to the User Manual of MICS.

Display CMU				Interface MICS					
Cooling	MICS	Com-pressor	Buzzer	Message (Window, E-mail)	JAC	CMU	CCA	T _{RS}	He
 blink	 bright	 bright		Cooler function not optimal. Call Bruker	 bright	 bright	 bright	 bright	 bright
 blink	 bright	 bright		Cooler function not optimal. Call Bruker	 bright	 bright	 bright	 bright	 bright
 blink	 bright	 bright		Cooler function not optimal. Call Bruker	 bright	 bright	 bright	 bright	 bright

Continued on next page

i In the case of a complete failure of the cryogenic refrigerator, the helium contained in the helium vessel will be sufficient to cool the magnet system for **at least 7 days**. If solving the issue takes longer, it is necessary to refill helium at all time (refer to supplied Refill Procedure manual).

Continued from page before

Sensor/Value Log files in MICS	Possible reason	Solution	By
U _{PT100-RS0} out of range	Cable 4 Pin Cryostat to CMU disconnected	Check connections	Approved Customer Personnel
	Cable 4 Pin Cryostat to CMU defective	Replace cable	Bruker Service
	Sensor defective	Disable CMU Mag RS sensor in CMU Service GUI	Bruker Service
T _{RS0} < T _{min}	Cable 4 Pin Cryostat to CMU disconnected	Check connections	Approved Customer Personnel
	Cable 4 Pin Cryostat to CMU defective	Replace cable	Bruker Service
	Sensor defective	Disable CMU Mag RS sensor in CMU Service GUI	Bruker Service
T _{RS0} > T _{max}	Cable 4 Pin Cryostat to CMU disconnected	Check connections	Approved Customer Personnel
	Cable 4 Pin Cryostat to CMU defective	Replace cable	Bruker Service
	Sensor defective	Disable CMU Mag RS sensor in CMU Service GUI	Bruker Service
	Cooling power too low	Check pressure values on compressor with specifications. Refer to "During Operation of the Cryogenic Refrigerator" on page 73	Bruker Service
	Gap on first stage too big	Check gap. Refer to "Cool- ing down to 4.2 K" on page 76	Bruker Service

Continued on next page

Continued from page before

Display CMU				Interface MICS					
Cooling	MICS	Com-pressor	Buzzer	Message (Window, E-mail)	JAC	CMU	CCA	T _{RS}	He
 blink	 bright	 bright		Cooler function not optimal. Check system status	 bright	 bright	 bright	 bright	 bright
 blink	 bright	 bright		Cooler function not optimal. Call Bruker	 bright	 bright	 bright	 bright	 bright
 blink	 bright	 bright		Cooler function not optimal. Call Bruker	 bright	 bright	 bright	 bright	 bright

















Continued on next page

Continued from page before

Sensor/Value Log files in MICS	Possible reason	Solution	By
$U_{PT100 RS1}$ out of range	Cable 4 Pin Cryostat to BSMS Mag RS disconnected	Check connections	Approved Customer Personnel
	BSMS Mag RS cable defective	Replace cable	Bruker Service
	BSMS Mag RS defective	Replace BSMS Mag RS box	Bruker Service
	Sensor defective	Disable sensor in CMU Service GUI	Bruker Service
$T_{RS1} < T_{min}$	Cable 4 Pin Cryostat to VTA Mag RS disconnected	Check connections	Approved Customer Personnel
	Mag RS box cable defective	Replace Mag RS box cable	Bruker Service
	Mag RS box defective	Replace Mag RS box	Bruker Service
	Sensor defective	Disable sensor in CMU Service GUI	Bruker Service
$T_{RS1} > T_{max}$	Cable 4 Pin Cryostat to VTA Mag RS disconnected	Check connections	Approved Customer Personnel
	Cable 4 Pin Cryostat to Mag RS Box defective	Replace cable	Bruker Service
	Sensor defective	Disable BSMS Mag RS in CMU Service GUI	Bruker Service
	Cooling power too low	Check pressure values on compressor with specifications. Refer to "During Operation of the Cryogenic Refrigerator" on page 73	Bruker Service
	Gap on first stage too big	Check gap. Refer to "Cooling down to 4.2 K" on page 76	Bruker Service

Continued on next page

Continued from page before

Display CMU				Interface MICS						
Cooling	MICS	Com-pressor	Buzzer	Message (Window, E-mail)	JAC	CMU	CCA	T _{RS}	He	
 blink	 bright	 bright		Helium measurement failed. Check system status	 bright	 bright	 bright	 bright	 bright	
 blink	 bright	 blink		Compressor off. Check compressor status	 bright	 bright	 bright	 bright	 bright	













































Continued on next page

Continued from page before

Sensor/Value Log files in MICS	Possible reason	Solution	By
U _{He} -Sensor out of range	Cable from helium sensor to console disconnected	Check connections	Approved Customer Personnel
	Electronic failure	Check helium log file	Approved Customer Personnel
	Calibration missing	Calibrate helium sensor in MICS GUI	Bruker Service
	Cable from sensor to console defective	Replace cable	Bruker Service
	Helium sensor defective	Replace helium sensor	Bruker Service
Compressor off	Compressor power supply failure	Check connections	Approved Customer Personnel
	Cooling water failure	Check water chiller	Bruker Service
	Compressor not operating	Check compressor. Refer to the manual of the cryogenic refrigerator	Bruker Service

Continued on next page

Continued from page before

Display CMU				Interface MICS					
Cooling	MICS	Com-pressor	Buzzer	Message (Window, E-mail)	JAC	CMU	CCA	T _{RS}	He
 blink	 bright	 blink		Compressor function not optimal. Call Bruker	 bright	 bright	 bright	 bright	 bright
 blink	 bright	 blink		Cooling water temperature too high. Check chiller	 bright	 bright	 bright	 bright	 bright
 blink	 bright	 blink		Compressor function not optimal. Call Bruker	 bright	 bright	 bright	 bright	 bright
 blink	 bright	 blink		Cooling water flow too low. Check chiller	 bright	 bright	 bright	 bright	 bright
 bright	 bright	 bright		CMU e-mail problem. Check settings/connection	 bright	 bright	 bright	 bright	 bright
-/-	-/-	-/-		Cooler funktion not optimal. Call Bruker	 bright	 bright	 bright	 bright	 bright



























Continued on next page

Continued from page before

Sensor/Value Log files in MICS	Possible reason	Solution	By
U_T , Cooling Water out of range	Cable at CCA or CMU disconnected	Check connections	Approved Customer Personnel
	CCA cable or CCA defective	Replace CCA cable or CCA	Bruker Service
$T_{\text{Cooling Water}} > T_{\text{max}}$	Cooling water problem	Check chiller loop	Approved Customer Personnel
U_Q , Cooling Water out of range	Cable at CCA or CMU disconnected	Check connections	Approved Customer Personnel
	CCA cable or CCA defective	Replace CCA cable or CCA	Bruker Service
$Q_{\text{Chiller}} < Q_{\text{min}}$	Cooling water problem	Check chiller loop	Approved Customer Personnel
JAC can not send e-mail	E-mail setting incorrect	Check settings	Approved Customer Personnel
	LAN cable disconnected	Check LAN connections	Approved Customer Personnel
JAC internal error	JAC defective	Reboot JAC. If not solved, replace JAC.	Bruker Service

Continued on next page

Continued from page before

Display CMU				Interface MICS					
Cooling	MICS	Com-pressor	Buzzer	Message (Window, E-mail)	JAC	CMU	CCA	T _{RS}	He
-/-	-/-	-/-		Power failure. RZ system off	 bright	 bright	 bright	 bright	 bright
-/-	-/-	-/-		Connection to JAC failed. Check system status <i>Remarks: compressor switched off to avoid underpressure</i>	 bright	 bright	 bright	 bright	 bright
 blink	 bright	 bright		Connection to BSMS failed. Check BSMS status	 bright	 bright	 bright	 bright	 bright
 blink	 bright	 bright		Cooler function not optimal. Check system status	 bright	 bright	 bright	 bright	 bright



























Continued on next page

Continued from page before

Sensor/Value Log files in MICS	Possible reason	Solution	By
JAC power failure	CMU power supply disconnected or JAC power switch off	Check JAC and CMU connections and JAC switch	Approved Customer Personnel
	CMU cable disconnected	Check CMU connections	Approved Customer Personnel
	JAC power supply cable defective	Replace cable	Bruker Service
	CMU cable defective	Replace cable	Bruker Service
	JAC power supply defective	Replace power supply	Bruker Service
JAC connection missing	CMU power supply disconnected or JAC power switch off	Check JAC and CMU connections and JAC switch	Approved Customer Personnel
	CMU-JAC power cable disconnected	Check connections	Approved Customer Personnel
	JAC power supply cable defective	Replace cable	Bruker Service
	CMU-JAC LAN cable defective	Replace cable	Bruker Service
	CMU power supply defective	Replace power supply	Bruker Service
BSMS connection missing	BSMS LAN cable disconnected	Check BSMS LAN connections	Approved Customer Personnel
	BSMS or console switched off	Restart BSMS or console	Approved Customer Personnel
ELCB firmware too old	ELCB firmware too old	Download the newest ELCB firmware on ELCB	Approved Customer Personnel

Continued on next page

Continued from page before

Display CMU				Interface MICS					
Cooling	MICS	Com-pressor	Buzzer	Message (Window, E-mail)	JAC	CMU	CCA	T _{RS}	He
 blink	 bright	 bright		Heater power too high. Call Bruker	 bright	 bright	 bright	 bright	 bright
 blink	 bright	 bright		Heater power too low. Call Bruker	 bright	 bright	 bright	 bright	 bright
 blink	 bright	 bright		Cooler function not optimal. Call Bruker	 bright	 bright	 bright	 bright	 bright
 blink	 bright	 bright		Cooler off. Helium evaporating. Call Bruker	 bright	 bright	 bright	 bright	 bright
 blink	 bright	 bright		Helium pressure too high. Call Bruker	 bright	 bright	 bright	 bright	 bright



























Continued on next page

Continued from page before

Sensor/Value Log files in MICS	Possible reason	Solution	By
Heater power above set value	Pressure is below set value	Check for leaks in the helium flow system	Bruker Service
	Pressure can not be reached due to leak	Check for leaks in the helium flow system	Bruker Service
Heater power below set value	Gas pressure inside compressor too low	Check gas pressure values of the compressor. Refill helium if not correct.	Bruker Service
	Rotary valve defective	Check operation status of the rotary valve. Replace rotary valve if necessary	Bruker Service
	Cold head power too low	Replace cold head	Bruker Service
Helium pressure below set value	Cable from pressure sensor to CMU disconnected	Check connections	Approved Customer Personnel
	CMU controller defective	Replace CMU	Bruker Service
	Heater defective	Check heater resistance. If broken replace heater	Bruker Service
Helium pressure below lowest limit	Cable from pressure sensor to CMU disconnected	Check connections	Approved Customer Personnel
	CMU controller defective	Replace CMU	Bruker Service
	Heater defective	Check heater resistance. If broken replace heater	Bruker Service
Helium pressure above set value	Cooling power too low.	Check heater power. If zero, refer to Heater power < 50 mW	Bruker Service

Continued on next page

Continued from page before

Display CMU				Interface MICS					
Cooling	MICS	Com-pressor	Buzzer	Message (Window, E-mail)	JAC	CMU	CCA	T _{RS}	He
 blink	 bright	 bright		<p>Cooler off. Helium evaporating. Call Bruker</p> <p><i>Remarks: compressor switched off to avoid underpressure after 15 min</i></p>	 bright	 bright	 bright	 bright	 bright
-/-	-/-	-/-		<p>Connection to CMU failed. Check CMU status</p> <p><i>Remarks: compressor switched off to avoid underpressure after 15 min</i></p>	 bright	 bright	 bright	 bright	 bright
 blink	 bright	 blink		<p>Connection to CCA failed. Check CCA status</p> <p><i>Remarks: compressor switched off to avoid underpressure after 15 min</i></p>	 bright	 bright	 bright	 bright	 bright
 blink	 blink	 bright		No message	-/-	-/-	-/-	-/-	-/-

Continued on next page

Continued from page before

Sensor/Value Log files in MICS	Possible reason	Solution	By
Pressure out of range	Cable from pressure sensor to CMU disconnected	Check connections	Approved Customer Personnel
	Pressure sensor defective	Replace pressure sensor	Bruker Service
CMU off	CMU cable disconnected	Check connections	Approved Customer Personnel
	CMU cable defective	Replace CMU cable	Bruker Service
	CMU defective	Replace CMU	Bruker Service
CCA off	CCA cable disconnected	Check connections	Approved Customer Personnel
	CCA cable defective	Replace CCA cable	Bruker Service
	CCA defective	Replace CCA	Bruker Service
MICS or PC off	Console workstation down	Restart workstation	Approved Customer Personnel
	MICS software not running	Restart MICS. MICS has to run at all time	Approved Customer Personnel

Continued on next page

Continued from page before

Display CMU				Interface MICS					
Cooling	MICS	Com-pressor	Buzzer	Message (Window, E-mail)	JAC	CMU	CCA	T _{RS}	He
 blink	 bright	 bright		Helium measurement failed. Check system status	 bright	 bright	 bright	 bright	 bright
 blink	 bright	 bright		Helium level below optimum. Refill helium	 bright	 bright	 bright	 bright	 bright
 blink	 bright	 bright		Helium level low. Refill helium	 bright	 bright	 bright	 bright	 bright









Continued on next page

Continued from page before

Sensor/Value Log files in MICS	Possible reason	Solution	By
Data update missing	Cable from helium sensor disconnected	Check connections	Approved Customer Personnel
	Calibration missing	Calibrate helium sensor in MICS GUI	Bruker Service
He-Level < 85 %	Helium leak	Refill helium. Call Bruker	Approved Customer Personnel
	Cooling power too low.	Check pressure values on compressor with specifications. Refer to "During Operation of the Cryogenic Refrigerator" on page 73	Bruker Service
	Rotary valve defective	Check operation status of the rotary valve. Replace rotary valve if necessary	Bruker Service
	Cold head power too low	Replace cold head	Bruker Service
He-Level < 70 %	Helium leak	Refill helium. Call Bruker	Approved Customer Personnel
	Cooling power too low.	Check pressure values on compressor with specifications. Refer to "During Operation of the Cryogenic Refrigerator" on page 73	Bruker Service
	Rotary valve defective	Check operation status of the rotary valve. Replace rotary valve if necessary	Bruker Service
	Cold head power too low	Replace cold head	Bruker Service

Continued on next page

Continued from page before

Display CMU				Interface MICS					
Cooling	MICS	Com-pressor	Buzzer	Message (Window, E-mail)	JAC	CMU	CCA	T _{RS}	He
 blink	 bright	 bright		Helium level too low. Refill helium	 bright	 bright	 bright	 bright	 bright

Continued on next page

Continued from page before

Sensor/Value Log files in MICS	Possible reason	Solution	By
He-Level < 40 %	Helium leak	Refill helium. Call Bruker immediately.	Approved Customer Personnel
	Cooling power too low.	Check pressure values on compressor with specifications. Refer to "During Operation of the Cryogenic Refrigerator" on page 73	Bruker Service
	Rotary valve defective	Check operation status of the rotary valve. Replace rotary valve if necessary	Bruker Service
	Cold head power too low	Replace cold head	Bruker Service

6.2.7 During De-energizing and Warming up

Indicator	Possible reason	Solution	By
The magnet system quenches during de-energizing.	The helium level was too low for de-energizing.	Refill helium at least to the minimum allowed level (see Appendix Technical Data).	Bruker Service
	The Power Supply is defective.	Replace Power Supply.	Bruker Service
	The main current is oscillating.	Replace Power Supply.	Bruker Service
The shim current can not be set correctly.	The control cable is not connected correctly to the current lead and/or the Power Supply.	Connect the control cable to the current lead and to the Power Supply correctly.	Bruker Service
	The switch "Main Coil/OFF/Shim Coil" is not on the "Shim Coil" position.	Switch "Main Coil/OFF/Shim Coil" on the "Shim Coil" position.	Bruker Service
High helium flow after breaking vacuum.	Remaining cryogenic agents in the inner vessels.	Remove liquid helium.	Bruker Service
Vacuum still remains after 12 hours.	Vacuum Valve is closed.	Open Vacuum Valve. Block it if necessary.	Bruker Service
RT vessel is wet and cold.	Cryostat is still cold.	Wait until RT vessel is dry and warm. Check PT 100 temperature sensors.	Bruker Service
RT bore wet and cold before disassembling.	Cryostat is still cold.	Wait one more day. Do not open a cryostat before the room temperature bore tube is warm and dry!	Bruker Service

6.2.8 During Operation of the Cryogenic Refrigerator

i In the case of a complete failure of the Cryogenic Refrigerator, the helium contained in the helium vessel will be sufficient to cool the magnet for at least 3 days. If solving the issue takes longer, it is necessary to refill helium at all time (refer to supplied Refilling Procedure).

i In case of any issue or failure specified in the following table where the intervention of the operator is necessary, make sure the start button of the compressor is switched off and the power supply of the compressor is disconnected.
 After resolving the issue, connect the power supply and push the start button of the compressor.
 If the compressor does not start immediately, press the temperature and the pressure switch for reset and after this the start button on the compressor.
 For problems not specified in this chapter refer to the supplied manual of the Cryogenic Refrigerator.

Indicator	Possible reason	Solution	By
Compressor is not operating.	No power supply or power supply interrupted.	Check the power supply to the compressor and verify that it meets the system requirements.	Approved Customer Personnel
	Circuit breaker OFF.	Check that the circuit breaker on the front panel of the compressor is ON. Check for possible causes why the circuit breaker switched off.	Approved Customer Personnel
		Check for possible causes why the circuit breaker switched off.	Approved Customer Personnel
	Pressure switch tripped	Reset the pressure switch located at the bottom of the front panel of the compressor.	Approved Customer Personnel
	Temperature switch tripped	Reset the temperature switch located at the bottom of the front panel of the compressor.	Approved Customer Personnel

Continued on next page

Continued from page before

Indicator	Possible reason	Solution	By
Compressor is operating, but no pressure fluctuation visible (needles at the pressure gauges not oscillating).	Motor cord not connected at the compressor.	Connect the motor cord to the compressor.	Approved Customer Personnel
	Motor cord not connected.	Check the motor cord connection at the coupling in the middle of the motor cord at 10 m (skip, if motor cord is one piece).	Approved Customer Personnel
		⚠ WARNING: Hot Surfaces	
	Motor cord not connected at the rotary valve.	<ol style="list-style-type: none"> 1. Dismount the noise protection cover of the Rotary Valve Column. 2. Check the motor cord connection at the rotary valve. 3. Connect motor cord, if necessary. 4. Remount the noise protection cover. 	Approved Customer Personnel
		If the problem is still not solved, contact Bruker Service.	Approved Customer Personnel
	Aeroquip® connectors of the flex lines not correctly tightened at the compressor.	Tighten the Aeroquip® connectors correctly.	Bruker Service
	High and low pressure helium flex line reversed at the compressor.	Check if the flex lines are mounted correctly at the compressor respecting high and low pressure port.	Bruker Service
	Motor cord defective.	Check continuity of all four conductors in the motor cord. If not correct, replace the motor cord.	Bruker Service

Continued on next page

Continued from page before

Indicator	Possible reason	Solution	By
<i>Continue of:</i> Compressor is operating, but no pressure fluctuation visible (needles at the pressure gauges not oscillating).	Aeroquip® connectors of the flex lines tightened not correctly at the rotary valve.	Tighten the Aeroquip® connectors correctly.	Bruker Service
	High and low pressure helium flex line reversed at the rotary valve.	Check if the flex lines are mounted correctly at the rotary valve respecting high and low pressure port.	Bruker Service
	Rotary valve is defective.	If possible, check if the rotary valve sound has changed since installation. If the typical sound is missing, the rotary valve might be defective and has to be exchanged. Replace the rotary valve.	Bruker Service
Compressor is operating, pressure fluctuation visible at the pressure gauges, extinguish short after start.	Water chiller not running.	Check possible reasons why the water cooler is not running. Start the water cooler.	Approved Customer Personnel
	Cooling water flow too low.	Check cooling water supply is sufficient (refer to supplied manual of the Cryogenic Refrigerator).	Approved Customer Personnel
	Cooling water flow too low due to icing, blockage, fouling or leak in the cooling water lines.	Search possible reason for the disturbance. Check the cooling water supply is as specified in the supplied manual of the Cryogenic Refrigerator and the manual of the water chiller.	Approved Customer Personnel
	Not correct environmental temperature (too high or too low).	Check the environmental temperature is as specified.	Approved Customer Personnel
	Not correct water temperature (too high or too low).	Check the cooling water temperature is as specified.	Approved Customer Personnel

Continued on next page

Continued from page before

Indicator	Possible reason	Solution	By
Compressor is operating, cryogenic refrigeration not sufficient.		Exclude all previous reasons of this list.	Approved Customer Personnel
	Not correct maintenance.	Check periodic maintenance work was made according to schedule (see " Maintenance Timetable " on page 84).	Approved Customer Personnel
		If the problem is still not solved, contact Bruker Service.	Approved Customer Personnel
		⚠ WARNING: Hot Surfaces	
	Connecting line between rotary valve and cold head not mounted correctly at the cold head.	Tighten the Aeroquip® connectors correctly. Check if the O-rings of the fitting are in correct position (see chapter " Mounting the Rotary Valve and Flex Lines " on page 60).	Bruker Service
	Low helium pressure inside the compressor helium circuit.	Recharge helium of high purity (He 5.0, 99.999%). Refer to supplied manual of the Cryogenic Refrigerator.	Bruker Service
	Low helium pressure due to small leak inside the compressor helium circuit.	<ol style="list-style-type: none"> 1. Leak detection with leak detector at connectors, flex lines, inside compressor, cold head, rotary valve, connecting line. 2. Eliminate leak, if possible. 3. Recharge helium of high purity (He 5.0, 99.999%). Refer to supplied manual of the Cryogenic Refrigerator. 	Bruker Service
High helium pressure inside the compressor.	Vent helium to the set value. Refer to supplied manual of the Cryogenic Refrigerator.	Bruker Service	

Continued on next page

Continued from page before

Indicator	Possible reason	Solution	By
<i>Continue of:</i> Compressor is operating, cryogenic refrigeration not sufficient.	Cold head contaminated.	Remount the cold head. Pump and flush the cold head. See chapter " Procedure in case of Cryogenic Refrigerator failure " on page 81	Bruker Service
	Cold head defective.	Replace the cold head. See chapter " Procedure in case of Cryogenic Refrigerator failure " on page 81	Bruker Service
	Cryogenic Refrigerator contaminated.	Replace the complete Cryogenic Refrigerator. See chapter " Procedure in case of Cryogenic Refrigerator failure " on page 81 and " Mounting the Cryogenic Refrigerator Parts " on page 53.	Bruker Service

6.3 Troubleshooting Work

6.3.1 After a Quench



Figure 6.1: Quench picture

A quench is the very fast de-energizing of the magnet by loss of its superconductivity. The stored magnetic energy is converted into heat, which promotes rapid evaporation of large quantities of helium. After an appearance of a quench contact Bruker Service immediately.



WARNING

Cryogenic Agents (see [page 21](#))

Quench (see [page 22](#))

Quench while in persistent mode:

1. Wait until the quench valves are closed and no helium evaporate out of the quench valves.
2. Wait until there is no helium vapor visible in the room or the ceiling to make sure there is sufficient oxygen in the room.
3. Switch off the alarm at the CMU.
4. Check the globes in the quench valves for their correct position.
5. Remove probe and shim system to prevent icing from the shim system.
6. Start the refill with liquid helium as soon as possible after the quench (within one hour after the quench; refer to the supplied Refilling Procedure).
7. Contact Bruker Service immediately.

-
- i** If the quench occurs unattended or helium transfer was not possible within one hour after the quench, it is recommended to warm up the system to 90 K.
-

6.3.2 Procedure in case of an alarm signal

If the temperature of the radiation shield exceeds the set maximum allowed temperature, an alarm will warn the operator (audible from the BMU, visible at the display of the BMU and the console via MICS).

Follow this procedure to fix the issue before contacting Bruker Service.

Note:

- Date and time.
- Temperature given on the display of the MICS.
- Turn the alarm of the CMU off.
- Which errors or warnings appear?
- What are the readings of the pressure gauges, run time counter etc. of the compressor?
- Which parts seems to be ok/not ok?
- How did the failure occur and what happened before failure?

6.3.3 Procedure in case of Cryogenic Refrigerator failure

In case of a failure of the Cryogenic Refrigerator the temperature of the shield T_{RS} will slowly rise to 200 K and the helium boil off to 250 ml/h. This is usual behavior.

In case of failure shorter than 7 days just restart the compressor of the Cryogenic Refrigerator. See remarks at chapter "During Operation of the Cryogenic Refrigerator" on page 73 for further information.

After restarting the Cryogenic Refrigerator, at least two days are necessary to recover the previous state of the magnet system. If the temperature and helium boil off does not decrease in the next two days call Bruker Service.

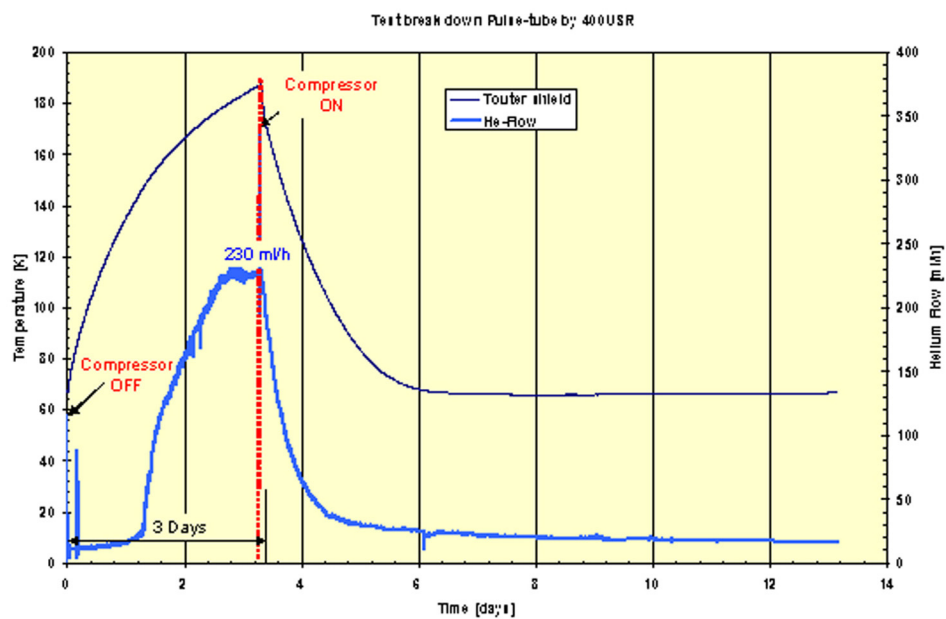

Figure 6.2: Temperature profile during Cryogenic Refrigerator failure

7 Maintenance

Maintenance must be performed only with approved qualification.

In case of doubt contact Bruker Service. For contact information see page 9 of this document.

7.1 Safety

Approved Persons

Bruker Service, Approved Customer Personnel

WARNING



Magnetic Fields (see [page 20](#))

Cryogenic Agents (see [page 21](#))

Electricity (see [page 21](#))

Gas under Pressure (see [page 21](#))

Low Temperatures (see [page 23](#))

Spontaneous Ignition and Explosion (see [page 23](#))

Hot Surfaces (see [page 25](#))

Personal protective equipment

Protective goggles

Protective gloves

Safety shoes

7.2 Cleaning

Procedure

- Clean the RT vessel of the magnet system, the magnet stand with dry or slightly damp cloth.
- Only use water and neutral detergents.
- Do not use volatile cleaning solvents.

7.3 Maintenance Timetable

Interval	Device	Work	By
daily	Cryostat	Check the helium flow.	Approved Customer Personnel
4.500 h (0.5 year)	Cryogenic Refrigerator	<ul style="list-style-type: none"> • Check the values at the high and low pressure gauges on the front panel of the compressor if the mean values are different and if an oscillation of the needles is noticeable. Refer to the supplied manual of the Cryogenic Refrigerator. Contact Bruker Service if values are different. • Check the proper operation of the water cooling unit. • Check system pressure, water flow and temperatures. Refer to the manual of the water cooling unit for further information. 	Approved Customer Personnel

Table 7.1: Maintenance Timetable - part 1

Continued on next page

Continued from page before

Interval	Device	Work	By
17.500 hours (2 years)	Cryogenic Refrigerator	<ul style="list-style-type: none"> • Replace the rotary valve. Refer to chapter "Replacement of the Rotary Valve and the Cold Head" on page 7-136. • Replace the adsorber of the compressor. Refer to the supplied manual of the Cryogenic Refrigerator. • Check the values at the high and low pressure gauges on the front panel of the compressor if the mean values are different and if an oscillation of the needles is noticeable. Refer to the supplied manual of the Cryogenic Refrigerator. <ul style="list-style-type: none"> - Pressure to high: Vent helium gas. Use the Service Kit. - Pressure to low: Refill helium gas of high purity (He 5.0, 99.999%). Use the Service Kit. 	Bruker Service
35.000 hours (4 years)	Cryogenic Refrigerator	<ul style="list-style-type: none"> • Replace rotary valve and cold head. Refer to chapter "Replacement of the Rotary Valve and the Cold Head" on page 7-136. • Replace the compressor. • Pump and flush the flex lines with helium gas of high purity (He 5.0, 99.999%) 	Bruker Service

Table 7.2: Maintenance Timetable - part 2

7.4 Maintenance Work at the Cryogenic Refrigerator

Approved Persons: Bruker Service only

8 Disassembling

8.1 Safety

Approved Persons: Bruker Service only



A Appendix

Warning Signs

Figures

Tables

Glossary / Abbreviations

Technical Data

Index

A.1 Warning Signs

Danger

Key Word and Symbol	17
---------------------------	----

Warning

Cryogenic Agents	21
Electricity	21
Gas under Pressure	22
Heavy Weights	24
Intended Use	18
Key Word and Symbol	17
Low Temperatures	23
Magnetic Field	20
Persons	18
Quench	22
Safety Devices	19
Signs and Labels	20
Slippage	23
Spare Parts	19
Spontaneous Ignition and Explosion	23

Caution

Incorrect Transportation	25
Key Word and Symbol	17

Notice

Key Word and Symbol	17
---------------------------	----

A.2 Figures

Figure 1.1:	General view a Magnet System with Aeon /RZ Cryostat	12
Figure 2.1:	Safety Devices of the RZ Cryostat.....	28
Figure 3.1:	Packaging (without surrounding panels).....	31
Figure 3.2:	Transportation by forklift - front side	33
Figure 3.3:	Transportation by forklift - rear side	33
Figure 3.4:	Attachment points for lifting equipment.....	34
Figure 3.5:	Instruction label for lifting equipment	34
Figure 5.1:	Start the Magnet Stand	40
Figure 5.2:	Stop the Magnet Stand	40
Figure 6.1:	Quench picture.....	78
Figure 6.2:	Temperature profile during Cryogenic Refrigerator failure.....	81
Figure A.1:	Dimension Cryostat - Front View	100
Figure A.2:	Dimension Cryostat - Top View	102
Figure A.3:	Helium Level Graph	104
Figure A.4:	Helium Level Sensor	105
Figure A.5:	Characteristic Curve PT 100.....	106
Figure A.6:	Characteristic Curve IBT	107
Figure A.7:	Wiring Diagramm Temperature Sensors	108
Figure A.8:	Fringe field plot	110
Figure A.9:	Current Lead 55 pins	111
Figure A.10:	Wiring Diagram Magnet	112
Figure A.11:	Wiring Diagram Magnet - Control	113
Figure A.12:	Wiring Diagram Magnet - Diagnostic and Temperature Sensors	114
Figure A.13:	Shorting Plug 55 pins	115

A.3 Tables

Table 7.1:	Maintenance Timetable - part 1	84
Table 7.2:	Maintenance Timetable - part 2	85
Table A.1:	Glossary	97
Table A.2:	Abbreviations	98
Table A.1:	Environmental conditions	99
Table A.2:	Dimension Cryostat - Front View	101
Table A.3:	Dimensions Cryostat - Top View	102
Table A.4:	Cryogenic Agents	103
Table A.5:	Helium Level Sensor	105
Table A.6:	Characteristic Values PT 100	106
Table A.7:	Characteristic Values IBT	107
Table A.8:	Specification of the Magnet	109
Table A.9:	Fringe Field Values	110
Table A.10:	Resistance at Room Temperature	117
Table A.11:	Heater currents	118
Table A.12:	Energizing assignment and currents	118
Table A.13:	Magnetic Center	119
Table A.14:	Cycling assignment (recommended only for 500Mhz and more)	119
Table A.15:	Energizing currents	120
Table A.16:	Deenergizing Assignment and Currents	121

A.4 Glossary / Abbreviations

Used term	Description
Box	Any kind of package used to protect sensitive parts during transportation.
Cryostat	The collective of all parts providing a temperature of 4 K inside for the superconducting magnet. The cryostat also provides the safety devices and the access ports for the cryogenic agents and electricity. The superconducting magnet inside the cryostat is not energized.
Dewar	Any kind of package used for transporting cryogenic agents like liquid helium or nitrogen.
Pressure Cylinder	Any kind of package used for transporting gaseous agents with a pressure up to 200 bar.
Magnet System	The collective of all parts necessary for the intended use. The superconducting magnet inside the cryostat is energized.

Table A.1: Glossary

Abbreviations	Description
ACD	Automatic Cooling Device
BSMS	Bruker Smart Magnet control System
BSVT	Bruker Smart Variable Temperature System
CCA	Compressor Control Adaptor
CMU	Cryostat Monitoring Unit
GUI	Graphical User Interface
JAC	Java Controller
MICS	Magnet Information and Control System
NMR	Nuclear Magnetic Resonance
RS	Radiation Shield
RT	Room Temperature; used as prefix of parts which are at room temperature
RVC	Rotary Valve Column
VTA	Variable Temperature Adapter

Table A.2: Abbreviations

A.5 Technical Data MS 500'89 Ascend Aeon

A.5.1 Technical Data Cryostat

Environmental conditions

	Value	Unit
Minimum surrounding temperature	7	°C
Maximum surrounding temperature	38	°C
Maximum relative humidity up to 31 °C	80	%
Maximum relative humidity between 31 °C and 40 °C linear decreasing	80-50	%

Table A.1: Environmental conditions

Identification Plate

The identification plate is on the right back side of the cryostat fixed at the bottom plate.

Contents of the identification plate:

- Address of the Manufacturer
- Magnet System Identifier
- Type
- Identification Number
- Magnet Identifier
- Serial Number
- Year of Construction
- Cryostat Identifier
- Specification Helium Vessel
- Specification Vacuum Chamber
- Weight (empty and completely filled) including magnet stand

Dimensions Cryostat

Front view

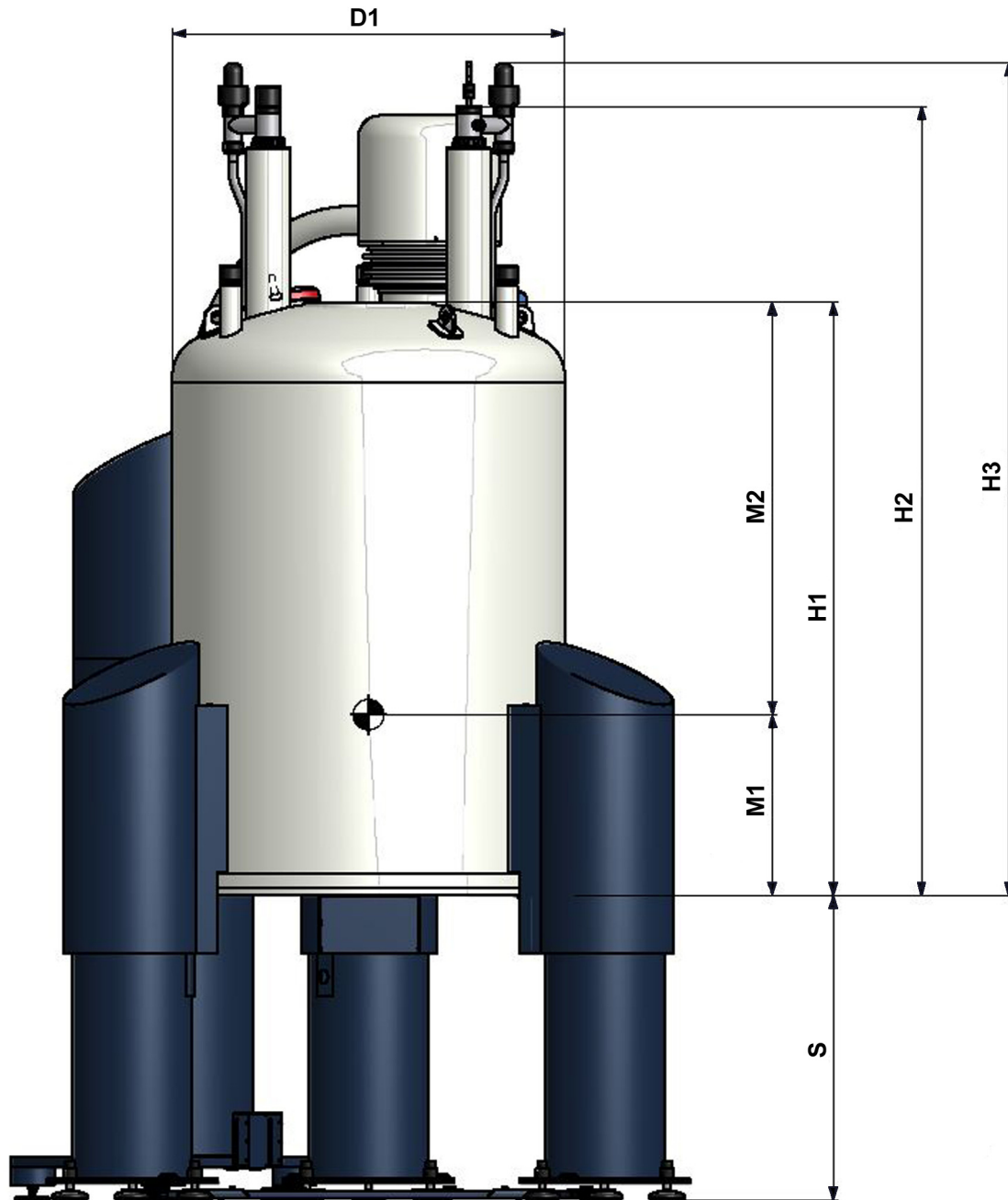

Figure A.1: Dimension Cryostat - Front View

Dimensions Cryostat	Value	Unit
C Operational Ceiling Height	2660	mm
D-RT Diameter RT Bore Tube	89	mm
D1 Diameter RT vessel	900	mm
D2 Diameter Bottom Plate	950	mm
H1 Height Cryostat (bottom plate to top flange)	1360	mm
H2 Height Cryostat (minimum height for transportation)	1809	mm
H3 Height Cryostat (bottom plate to flow system)	1908	mm
H4 Height Rotary Valve Column	1800	mm
S Height Magnet Stand (floor to bottom plate)	700	mm
M1 Distance magnetic Center to bottom flange (calculated)	refer to Table A.13, page 119	
M2 Distance magnetic center to top flange (calculated)	refer to Table A.13, page 119	

Table A.2: Dimension Cryostat - Front View

Top view

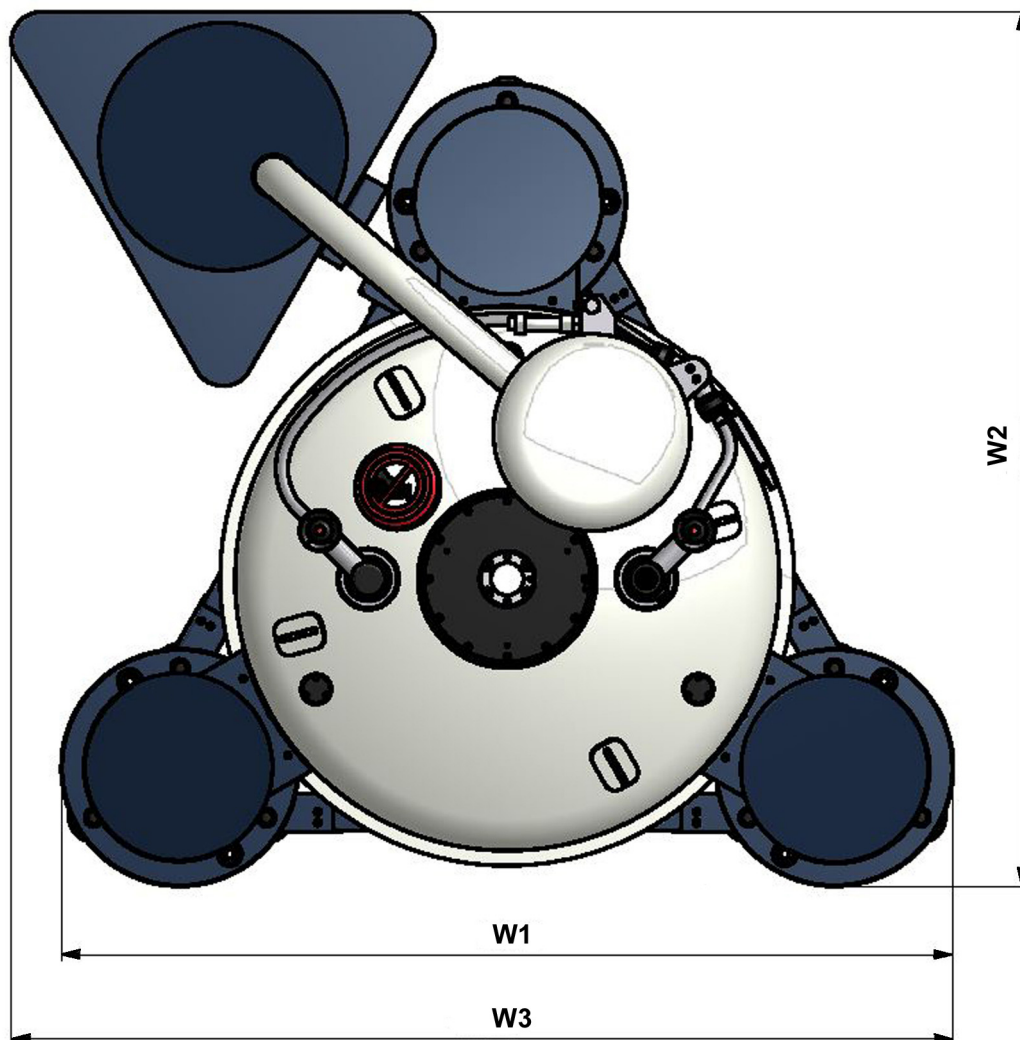

Figure A.2: Dimension Cryostat - Top View

Dimensions Cryostat	Value	Unit
W1 (Width side to side)	1476	mm
W2 (Width front to back with RVC)	1448	mm
W3 (Width side to side with RVC)	1556	mm
D3 ¹ (Diameter magnet stand)	1661	mm

Table A.3: Dimensions Cryostat - Top View

1. Keep at least an additional free space of 1.5 m around the magnet system for service.

Fill Volume, Evaporation Rate and Hold Time

Cryogenic Agents	Value	Unit
Helium vessel total volume	373	l
Helium refill volume	310	l
Helium evaporation rate	0	ml/h
Helium hold time ¹ with Cryogenic Refrigerator operating	3000	days
Helium hold time with Cryogenic Refrigerator not operating (at minimum allowed helium level)	7	days
Helium refill volume after Quench (cool down and refill)	350	l

Table A.4: Cryogenic Agents

1. Maximum time intervall between two fillings

Helium Level Graph

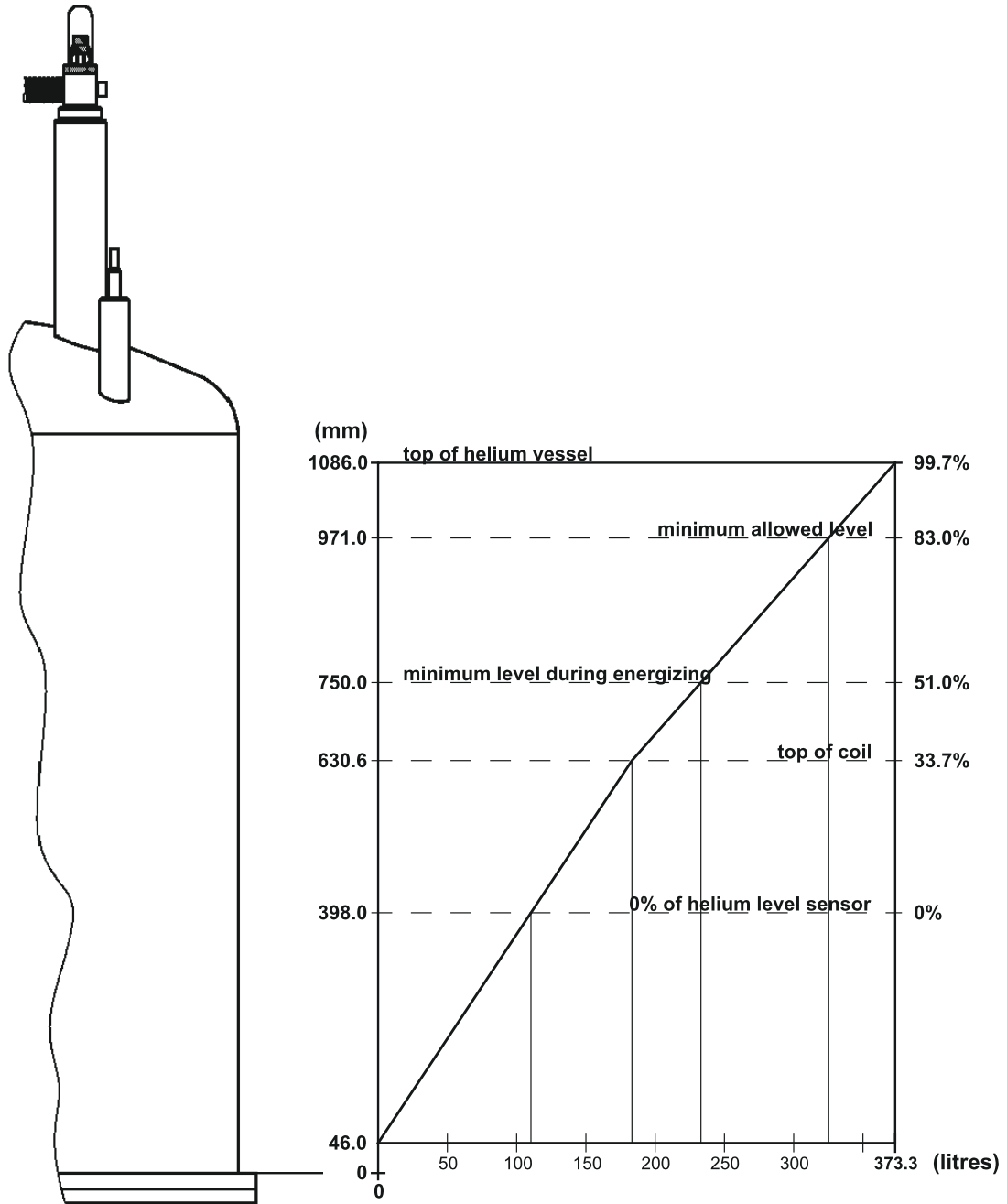

Figure A.3: Helium Level Graph

Helium Level Sensor

The Helium Level Sensor is inserted in the helium fill-in turret.

Helium Level Sensor	Material No.	Value	Unit
Level Sensor Type	Z58114	1300/690	
Overall length		1300	mm
Active length		690	mm
Calibration 0 %, Calibration resistor	Z28630 blue	140	Ω
Calibration 100 %, Calibration resistor	Z28628 black	15	Ω

Table A.5: Helium Level Sensor

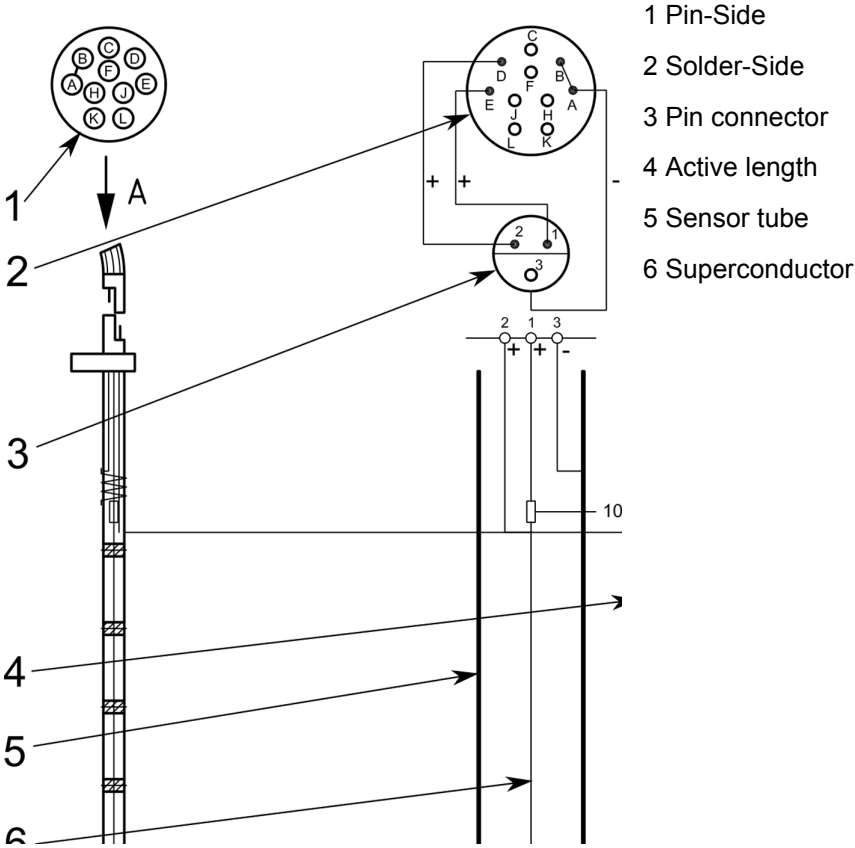

Figure A.4: Helium Level Sensor

Temperature Sensors

The temperature sensors (PT 100 and IBT) will be used to monitor the temperature of the magnets during cooling and warming up of the magnet system.

PT 100

i Measure the resistance with a maximum current of 1 mA.

	Temperature	Unit	Resistance	Unit
Room Temperature	293	K	107.8	Ω
	273	K	100.0	Ω
	250	K	91.0	Ω
	200	K	71.1	Ω
	150	K	50.9	Ω
	100	K	30.0	Ω
Liquid Nitrogen	77	K	20.1	Ω

Table A.6: Characteristic Values PT 100

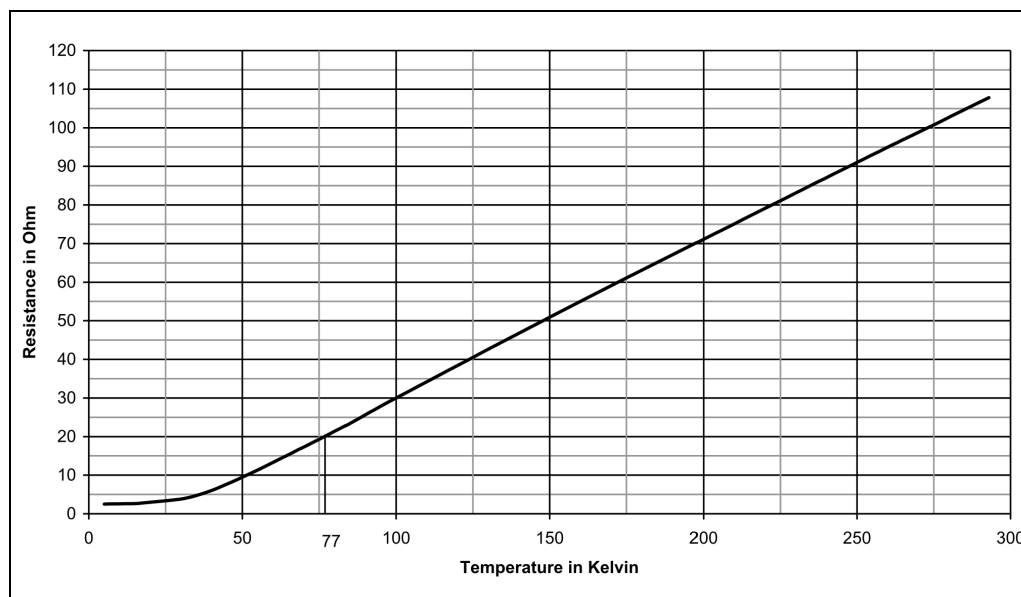

Figure A.5: Characteristic Curve PT 100

IBT Carbon Resistor

i Measure the Resistance with a maximum current of 0.1 mA.

	Temperature	Unit	Resistance	Unit
Room Temperature	300	K	220	Ω
Liquid Nitrogen	77	K	265	Ω
	40	K	300	Ω
	20	K	350	Ω
	10	K	420	Ω
	8	K	450	Ω
	6	K	500	Ω
	5	K	540	Ω
Liquid Helium	4.2	K	575	Ω

Table A.7: Characteristic Values IBT

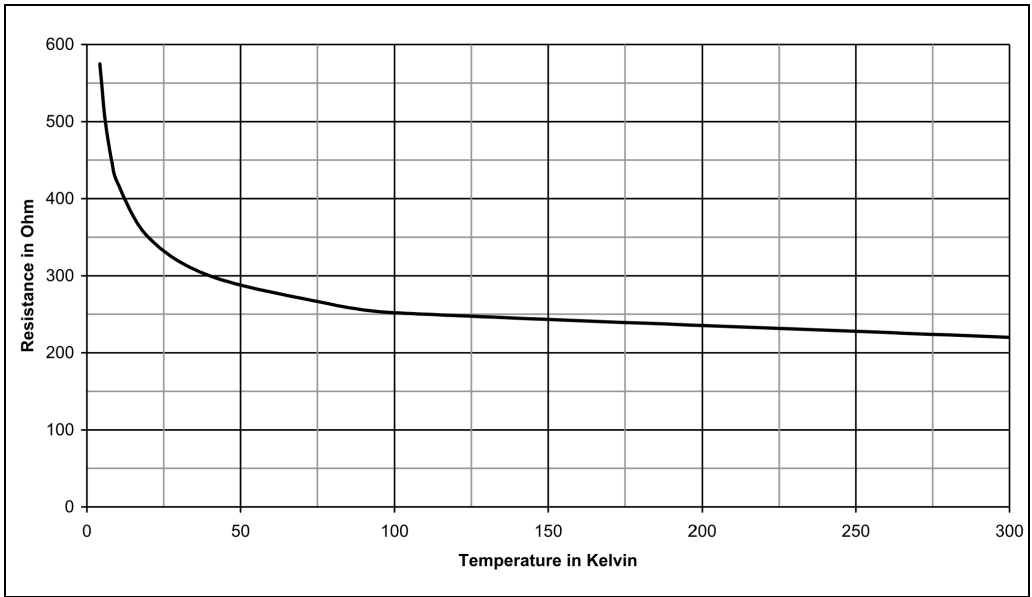

Figure A.6: Characteristic Curve IBT

Wiring Diagramm Temperature Sensors

(will be added after final design)

View from outside Feedthrough
Plate

Figure A.7: Wiring Diagramm Temperature Sensors

A.5.3 Technical Data Magnet

Technical Data Magnet	Value	Unit
Proton frequency	500	MHz
Central field	11.74	T
Coil inductance	42.94	H
Magnetic energy	736.6	kJ
Maximum drift rate	0.01	ppm/h
	5	Hz/h

Table A.8: Specification of the Magnet

Operating modes of the Magnet System:

Driven Mode

In the driven mode the current lead is mounted and the electricity is flowing through the power supply. The coils of the magnet can be charged and discharged.

Persistent Mode

In the persistent mode the electricity is flowing exclusively within the magnet. The circuit has no connection to the outside. The magnetic field cannot be switched off.

Fringe Field Plot

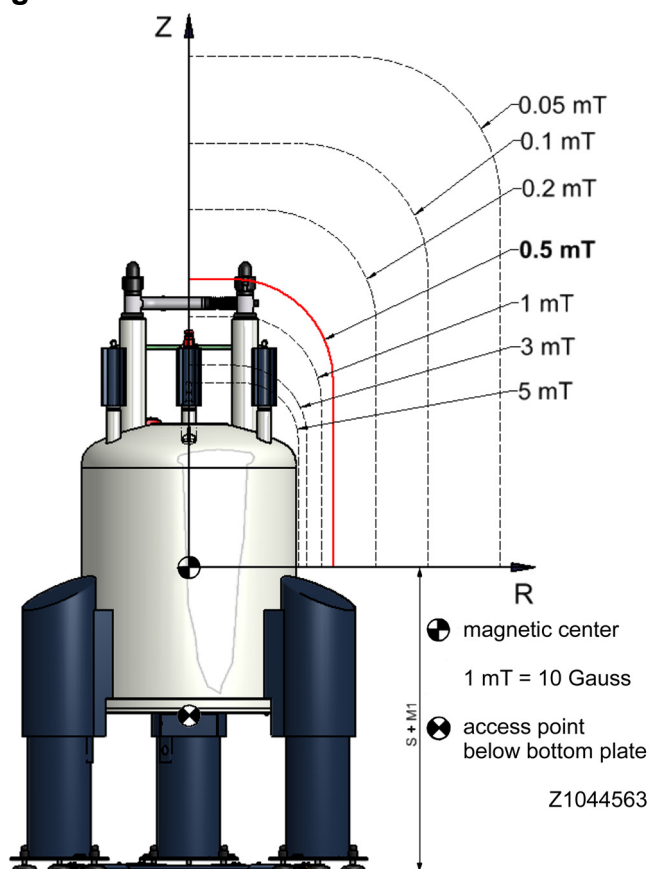
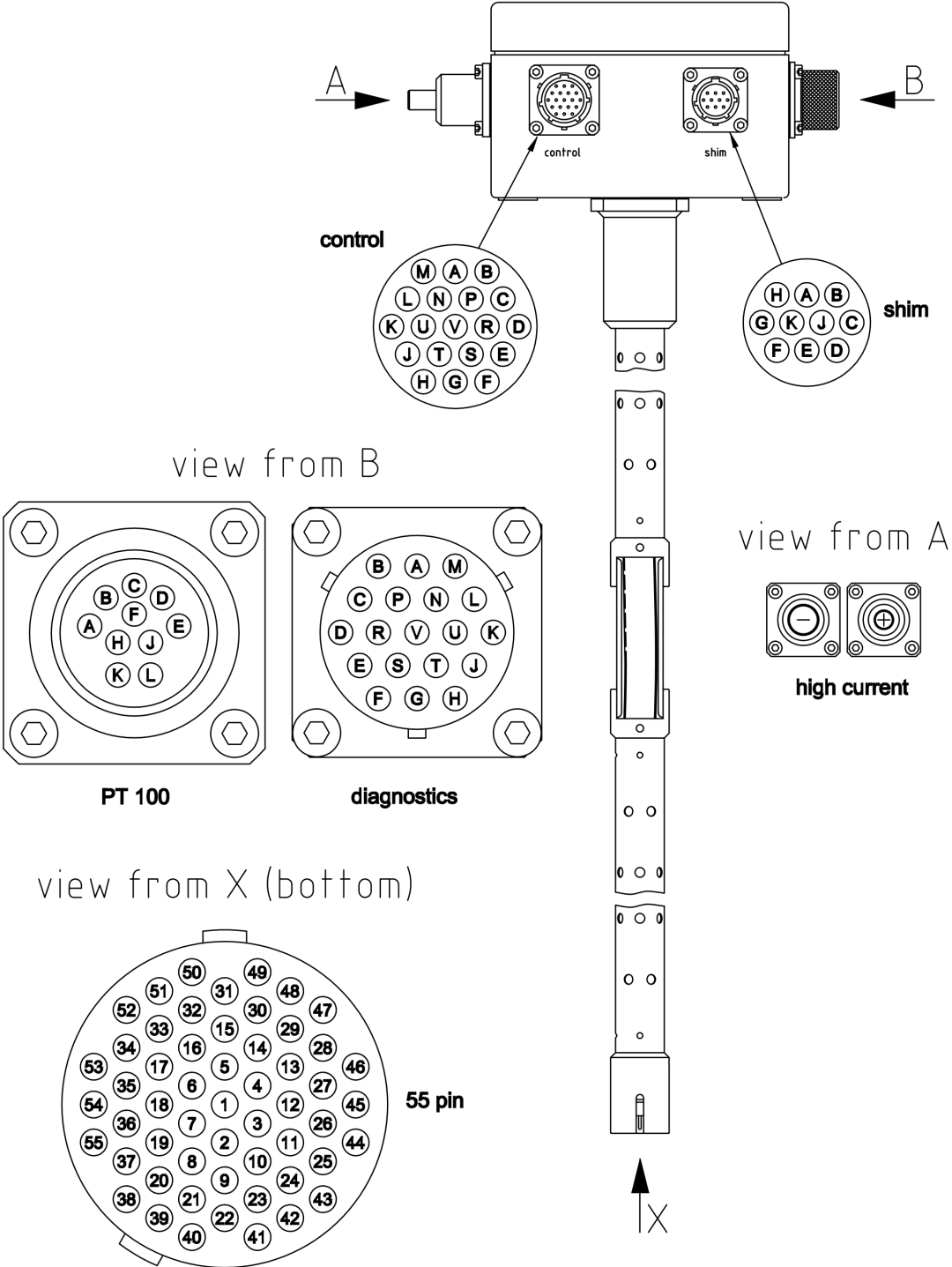

Figure A.8: Fringe field plot

Fringe Field	Unit	R max	Unit	Z max	Unit
200	mT	0.29	m	0.48	m
5.0	mT	0.50	m	0.88	m
3.0	mT	0.54	m	0.97	m
1.0	mT	0.62	m	1.21	m
0.5	mT	0.70	m	1.40	m
0.2	mT	0.92	m	1.73	m
0.1	mT	1.17	m	2.07	m
0.05	mT	1.52	m	2.49	m
max magnetic field B0 at access point				314	mT
max field gradient dB/dz at access point				4.8	T/m

Table A.9: Fringe Field Values

Current Lead



Z1029367

Figure A.9: Current Lead 55 pins

Wiring Diagram Magnet

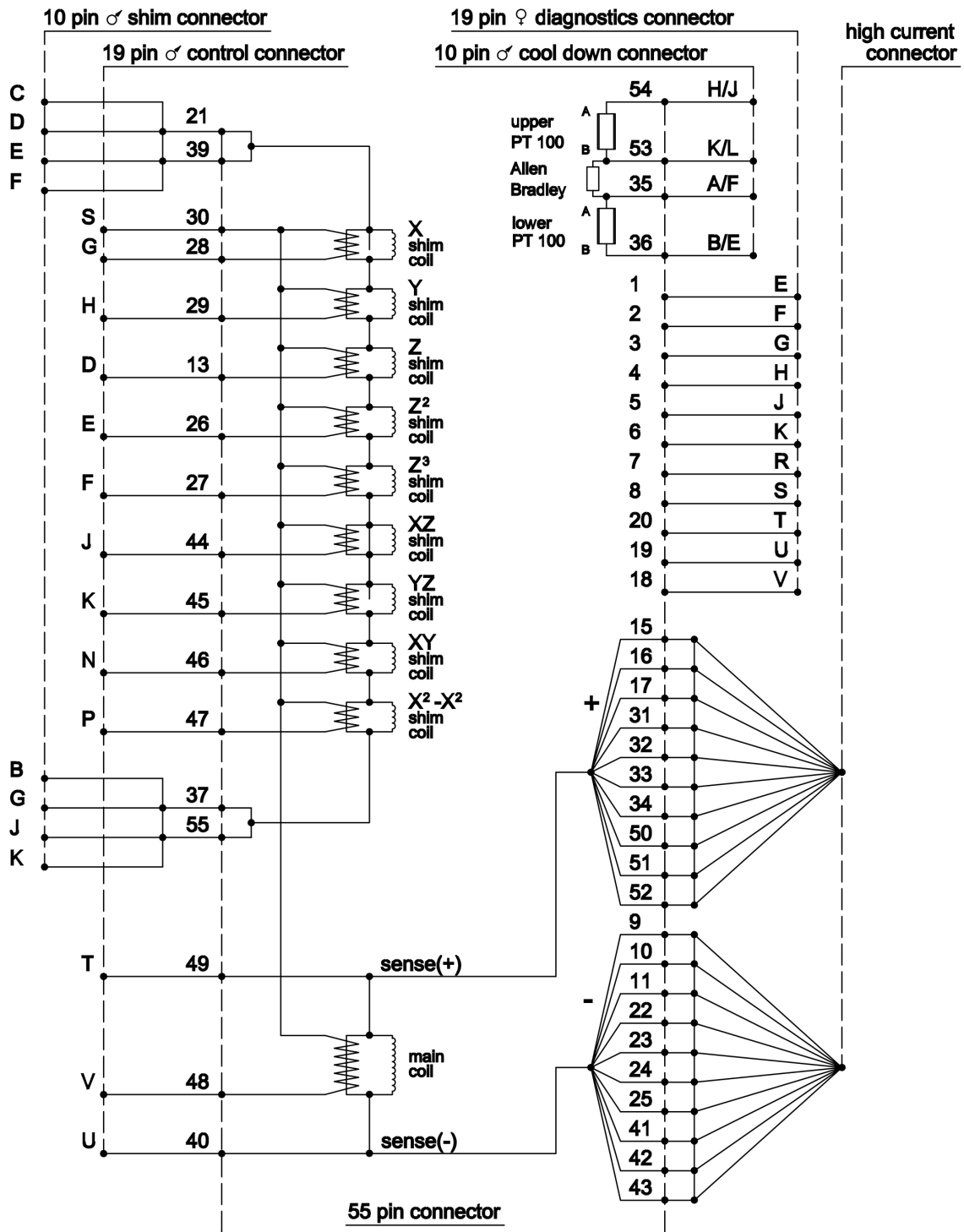

Z1030082

Figure A.10: Wiring Diagram Magnet

Wiring Diagram Magnet Control

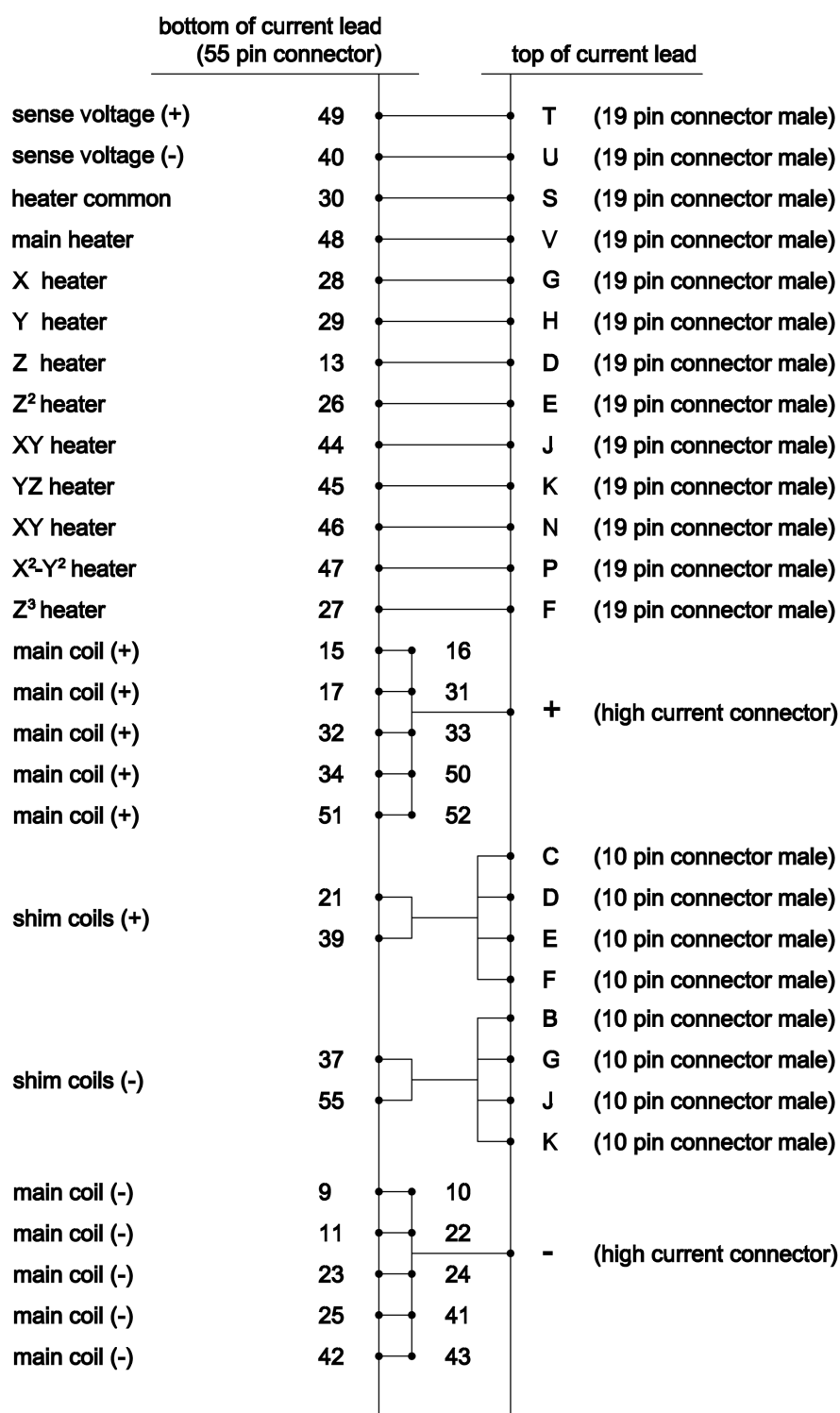

Z1029391

Figure A.11: Wiring Diagram Magnet - Control

Wiring Diagram Magnet Diagnostic and Temperature Sensors

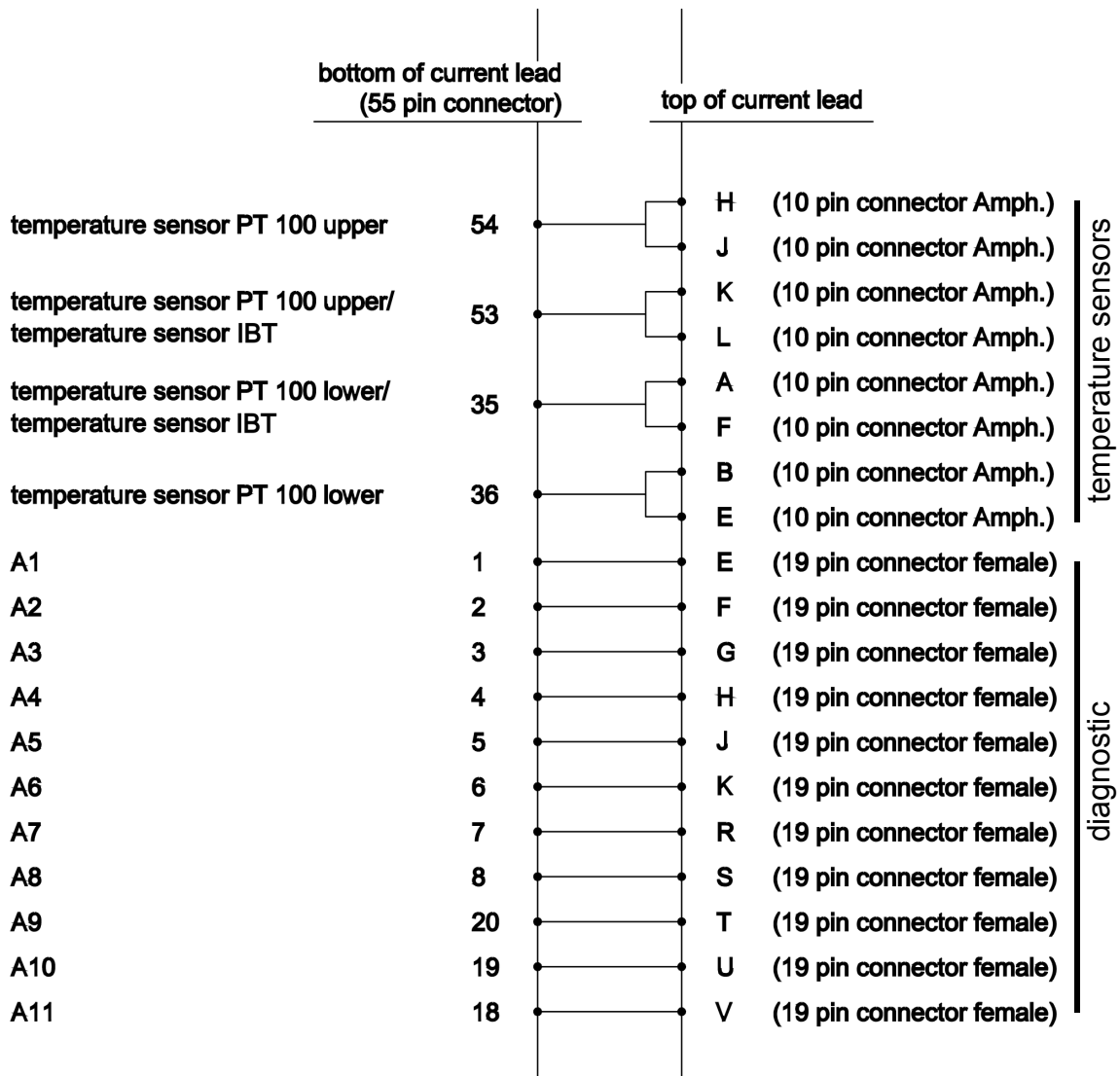

Z1029392

Figure A.12: Wiring Diagram Magnet - Diagnostic and Temperature Sensors

Shorting Plug

The shorting plug is plugged after removal of the current lead. After inserting the shorting plug the current flows through the shorting plug and no longer through the current lead and the power supply.

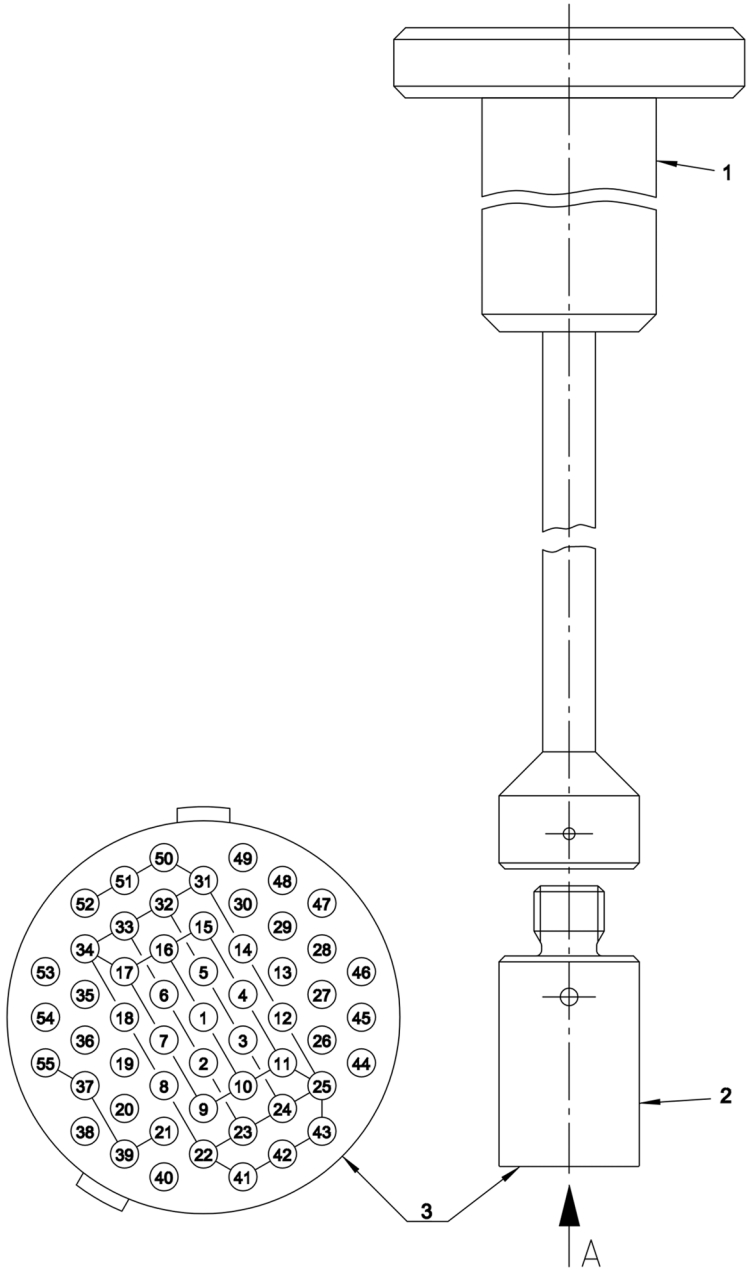

Z1029521

Figure A.13: Shorting Plug 55 pins
1 Shorting Plug Tool for fitting and removing the shorting plug
2 Shorting Plug
3 Shorting Plug - view from pin side

This side is intentionally left blank.

Resistance at Room Temperature

	Pin	Connector	Description	Value	Unit
From: To:	PIN V PIN S	19 PIN Con CONTROL 19 PIN Con CONTROL	Main Heater		Ω
From: To:	PIN D PIN S	19 PIN Con CONTROL 19 PIN Con CONTROL	Z Heater		Ω
From: To:	PIN G PIN S	19 PIN Con CONTROL 19 PIN Con CONTROL	X Heater		Ω
From: To:	PIN H PIN S	19 PIN Con CONTROL 19 PIN Con CONTROL	Y Heater		Ω
From: To:	PIN J PIN S	19 PIN Con CONTROL 19 PIN Con CONTROL	XZ Heater		Ω
From: To:	PIN K PIN S	19 PIN Con CONTROL 19 PIN Con CONTROL	YZ Heater		Ω
From: To:	PIN N PIN S	19 PIN Con CONTROL 19 PIN Con CONTROL	XY Heater		Ω
From: To:	PIN P PIN S	19 PIN Con CONTROL 19 PIN Con CONTROL	X ² -Y ² Heater		Ω
From: To:	PIN E PIN S	19 PIN Con CONTROL 19 PIN Con CONTROL	Z ² Heater		Ω
From: To:	PIN F PIN S	19 PIN Con CONTROL 19 PIN Con CONTROL	Z ³ Heater		Ω
From: To:	PIN C,D,E,F PIN B,G,J,K	10 PIN Con SHIM 10 PIN Con SHIM	Shim Coils +/-		Ω
From: To:	+ PIN T	High current Con 19 PIN Con CONTROL	High Current to Sense +		Ω
From: To:	+ -	High current Con High current Con	Main Coil		Ω
From: To:	- PIN U	High current Con 19 PIN Con CONTROL	High Current to Sense -		Ω
From: To:	PIN T PIN U	19 PIN Con CONTROL 19 PIN Con CONTROL	Sense + Sense -		Ω
From: To:	PIN C PIN S	10 PIN Con SHIM 19 PIN Con CONTROL	Shim Coil to Heater (common)		Ω
From: To:	PIN C PIN T	10 PIN Con SHIM 19 PIN Con CONTROL	Shim Coil to Main Coil		Ω
From: To:	PIN T PIN S	19 PIN Con CONTROL 19 PIN Con CONTROL	Sense to Heater (common)		Ω
From: To:		All Connectors Ground	Insulation Magnet to Cryostat		Ω
From: To:	PIN K PIN H	10 Pin cool down Con 10 Pin cool down Con	Upper temperature sensor PT 100		Ω
From: To:	PIN A PIN K	10 Pin cool down Con 10 Pin cool down Con	IBT Carbon temperature sensor		Ω
From: To:	PIN A PIN B	10 Pin cool down Con 10 Pin cool down Con	Lower temperature sensor PT100		Ω

Table A.10: Resistance at Room Temperature

Heater Currents



Heater Currents	Value	Unit
Main heater current		A
Shim heater current		A

Table A.11: Heater currents

Energizing Assignment and Currents

Check the "minimum helium level for energizing" (refer to Figure A.3, page 104)

During energizing the Z² shim heater must be permanently ON.

Energizing Currents [A]			Sense voltage [mV]	Remarks Bruker Test Site
0	to	120	4000	
120	to	170	2000	
170	to	190	1000	
190	to	205	500	
205	to		200	
Overshoot (0.25 % of final current)				
	to		50	
10 Minutes break at overshoot current				
	to		-50	
Total energizing time [min]				

Table A.12: Energizing assignment and currents

Magnetic Center



Refer to Figure A.1, page 100.

Magnetic Center	Value	Unit
Magnet center from bottom flange M1		mm
Magnet center from top flange M2		mm

Table A.13: Magnetic Center

Cycling Assignment and Shim Currents

(recommended only for 500MHz and more)

Cycling Assignment and Shim Currents	Value	Unit
Time between energizing and cycling (at least 12 h)		h
Time between cycling and shimming (at least 12 h)		h
Current rate		A/h
Z-Shim current		A
Z ² -Shim current		A
Z ³ -Shim current		A
X-Shim current		A
Y-Shim current		A
XZ-Shim current		A
YZ-Shim current		A
XY-Shim current		A
X ² -Y ² -Shim current		A
Frequency change due to cycling		kHz
Date and Signature		

Table A.14: Cycling assignment (recommended only for 500Mhz and more)

Energizing Currents



Energizing Currents	Value Bruker Test Site	Value Customer Site #1	Value Customer Site #2	Unit
Magnet main current				A
Z-Shim current				A
Z ² -Shim current				A
Z ³ -Shim current				A
X-Shim current				A
Y-Shim current				A
XZ-Shim current				A
YZ-Shim current				A
XY-Shim current				A
X ² -Y ² -Shim current				A
Magnetic center from bottom flange (measured)				mm
Magnetic center from top flange (measured)				mm
Date and Signature				

Table A.15: Energizing currents

Deenergizing Assignment and Currents

Deenergizing Currents [A]			Sense voltage [mV]	Remarks Bruker Test Site
	to	205	400	
205	to	190	1000	
190	to	0	2000	through external diodes
Total deenergizing time [min]				

Table A.16: Deenergizing Assignment and Currents

This side is intentionally left blank.

Magnet System Report

Helium level [%]	T RS [K]	Excess [mW]	Pressure [mbar]	Date, Time	Signature

A.6 Index

A

Attachment Point 34

C

Cleaning Staff 16

Cold Head 12

Complaint Process 32

Compressor 12

Connection Line 12

Cryogenic Agents 20, 21

Cryogenic Refrigerator 13, 81

D

Disturbances 50

Drop-off Plate 29

E

Electricity 21

Emergency 30

Emergency Exit 27

F

Fire Department 30

First Aid for Cold Burns 30

Flex Lines 12

I

Identification Plate 99

Intended Use 18

L

Liability 11

Low Temperatures 23

M

Magnet Stand 12

Magnetic Center 119

Magnetic Field 20

P

Portable Oxygen Monitor 26

Protective Clothes 26

Protective Gloves 26

Protective Goggles 26

Q

Quench 22, 78

Quench Valve 29

R

Rescue Equipment	30
Rotary Valve Column	12

S

Safety Devices	28
Safety Shoes	26
Shock Watch	32
Slippage	23
Spontaneous Ignition	23

T

Tilt Watch	32
Tilting	24

W

Warranty	11
----------------	----

Revision History List

Index:	Date:	Alteration Type:
00	December 2013	First release.





Bruker Corporation

info@bruker.com
www.bruker.com

Order No: ZTKS0157 / Z31921 / 00